

U-CONTROL UCA222

Ultra-Low Latency 2 In/2 Out USB Audio Interface with Digital Output

- Ultra-flexible audio interface connects your instruments, mixer, etc. with your computer for recording and playback
- Massive software bundle including Audacity audio editor, comprehensive podcasting software and over 150 virtual instruments and effect plug-ins downloadable at behringer.com
- Works with your PC or Mac computer—no setup or drivers required
- High-resolution 48 kHz converters for high-end audio quality
- Stereo Headphone output with dedicated Level control lets you monitor both input and output
- Additional S/PDIF optical output for direct digital conversion
- Powered via USB—no external power supply needed
- High-quality components and exceptionally rugged construction ensure long life
- Conceived and designed by BEHRINGER Germany



The fastest way to upgrade your mixer

Looking for a simple, affordable way to get your music into the digital realm? Or maybe you'd like to connect your computer to an external effects unit or recorder? Want to transfer your old cassette tapes to CD before the oxide falls off the tape? The fastest, easiest way to get analog audio into your computer is with the U-CONTROL UCA222 Audio Interface.

PC and Mac Ready

This ultra-compact, USB-powered device lets you connect your PC or Mac computer to virtually any piece of audio gear. It gets its power from your computer's USB bus, so no external power supply or batteries are required. And the UCA222 requires no special setup or drivers—just plug it in to a free USB port and start recording.

Versatility

The UCA222 features two analog mono inputs for connecting any line-level device, such as a mixer or tape deck, and

two analog mono outputs for connecting active speakers or studio monitors. On the digital side, the UCA222 provides USB connectivity and an additional S/PDIF optical output for direct analog-to-digital conversion. The stereo headphone output has a dedicated level control and allows you listen to either the input source or the computer output.

Imagine the possibilities...

When used as a professional interface between a mixing console and your computer, myriad options become available. Some of these might include connecting the UCA222's RCA outputs to the TAPE INPUT jacks of your mixer or active monitors, or directly into the input channels of the mixer. Connecting to mixer input channels gives you access to equalization and allows you to use the AUX Send features of your mixer to build extremely versatile monitor mixes for your recording sessions.

Continued on next page

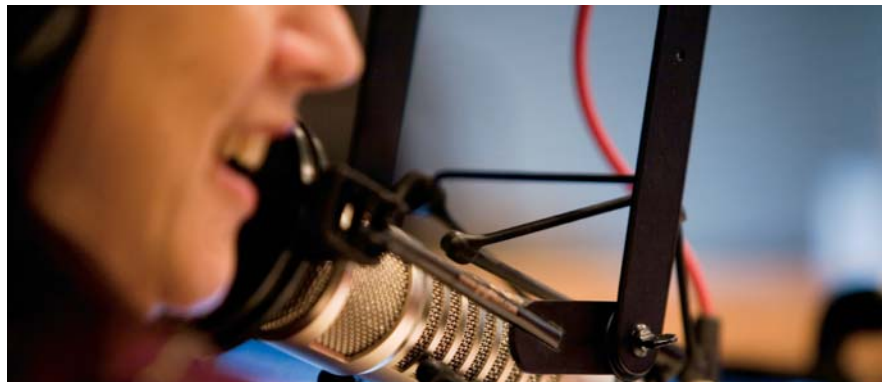

U-CONTROL UCA222

Tons of free software

Because you'll want to take full advantage of the UCA222's podcasting and recording potential we've included a massive software package including Audacity, Podifier, Juice, Podnova and Golden Ear. You're ready to go live on your Mac or PC computer right out of the box! You also get more than 100 virtual instruments and over 50 effects plug-ins, turning your computer into a complete home-based or mobile recording studio from input to output.

Value

For a fraction of the cost of an over-priced USB audio interface from those other guys, you can have state-of-the-art digital conversion, world-class recording and editing software, and hassle-free connectivity between your PC or Mac Computer and any piece of audio gear.

Bridging the gap between your music and the rest of the world—the BEHRINGER U-CONTROL UCA222.



Recording from a Mixer

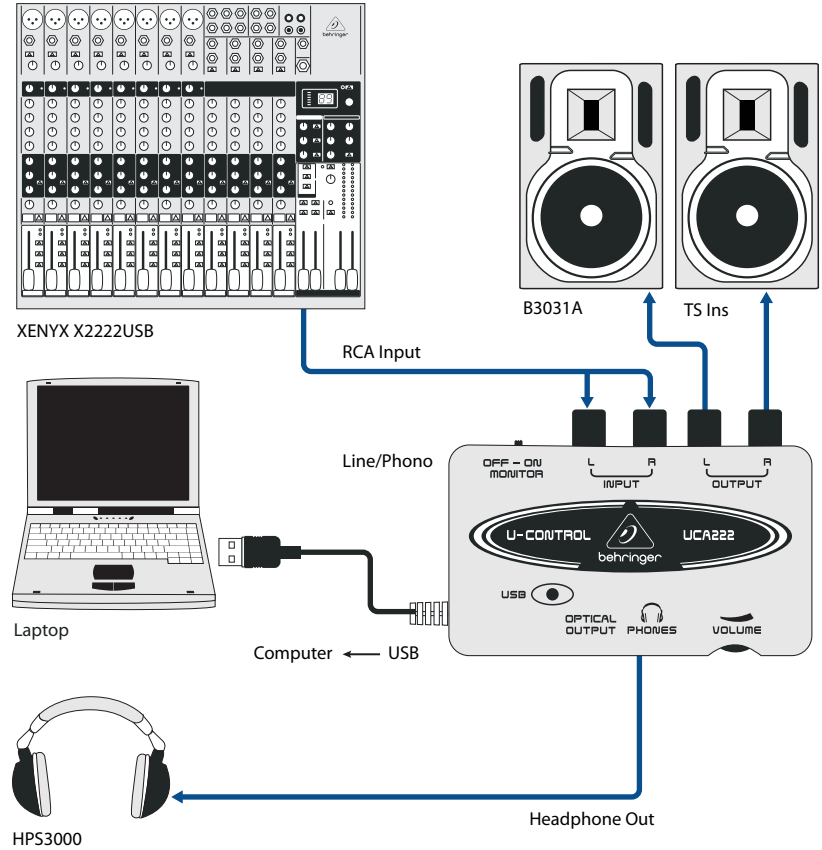

Recording with a Preamp

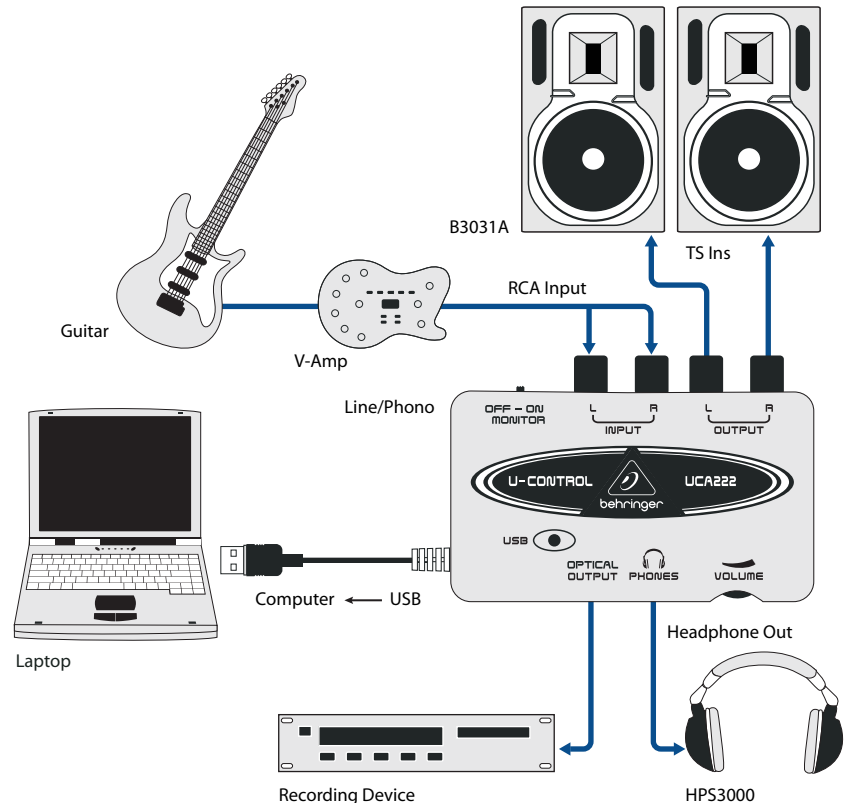

U-CONTROL UCA222

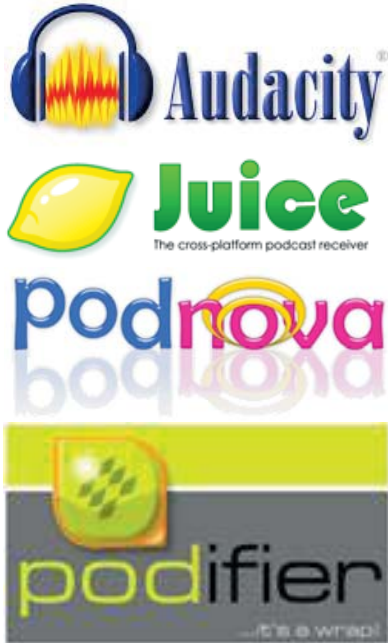

PC

Intel or AMD CPU, 400 MHz or higher
 Minimum 128 MB RAM
 USB 1.1 interface
 Windows XP, 2000 or higher

MAC

G3, 300 MHz or higher
 Minimum 128 MB RAM
 USB 1.1 interface
 Mac OS 9.0.4 or higher, 10.X or higher

Just a side note: Today an optical output might be much more attractive (especially for home customers) to connect the interface to your home cinema A/V receiver with its internal HQ D/A converters, than connecting to a digital stand alone recorder like DAT recorder or comparable.

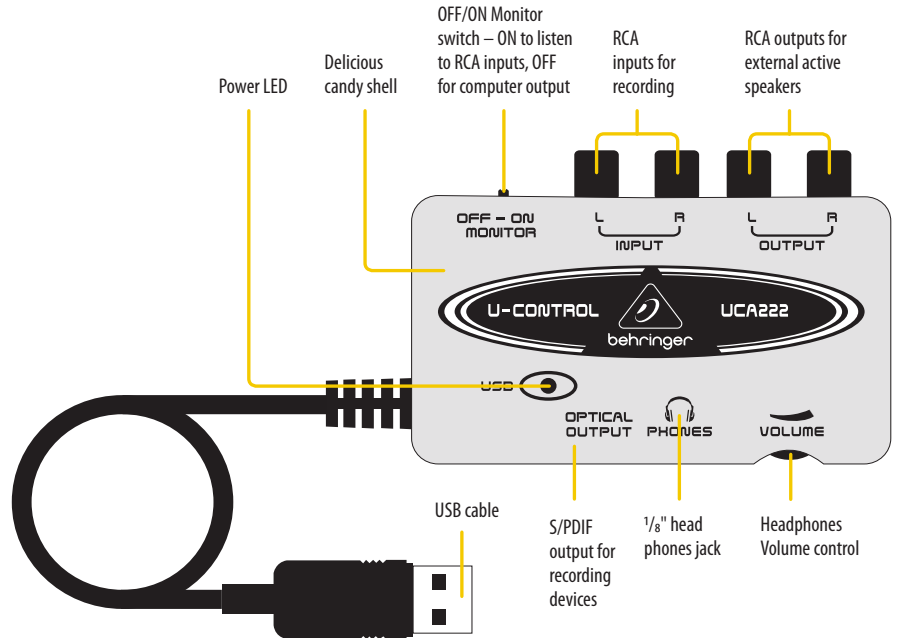

Specifications

Line In	
Connectors	RCA, unbalanced
Input impedance	approx. 27 kΩ
Max. input level	2 dBV
Line Out	
Connectors	RCA, unbalanced
Output impedance	approx. 400 Ω
Max. output level	2 dBV
Digital Output	
Socket	Toslink, optical cable
Output format	S/PDIF
Phones Out	
Socket	1/8" TRS stereo jack
Output impedance	approx. 50 Ω
Max. output level	-2 dBu, 2 x 3,7 mW @ 100 Ω

USB 1.1	
Connectors	type A
Digital Processing	
Converter	16-bit converter
Sample rate	32.0 kHz, 44.1 kHz, 48.0 kHz
System Data	
Frequency response	10 Hz to 20 kHz, ± 1 dB @ 44.1 kHz sample rate 10 Hz to 22 kHz, ± 1 dB @ 48.0 kHz sample rate
THD 0.05 %	typ. @ -10 dBV, 1kHz
Crosstalk	-77 dB @ 0 dBV, 1 kHz
Signal-to-noise ratio	A/D 89 dB typ. @ 1 kHz, A-weighted D/A 96 dB typ. @ 1 kHz, A-weighted

Power Supply	
USB connection	5 V, 100 mA max.
Dimensions/Weight	
Dimensions (H x W x D)	approx. 0.87 x 2.36 x 3.46" approx. 22 x 60 x 88 mm
Weight	approx. 0.22 lbs / approx. 0.10 kg

Please note these specifications are preliminary and conceptual in nature, and as such are subject to change as product development progresses. This information is supplied for market research purposes only and is not to be made public in any manner. This document is solely the property of The MUSIC Group, or one of its subsidiaries, and must be surrendered upon request of the owner.

For service, support or more information contact the BEHRINGER location nearest you:

Europe MUSIC Group Services EU GmbH
 Tel.: +49 2154 9206 4149 / Fax: +49 2154 9206 4199
USA/Canada MUSIC Group Services US Inc.
 Tel.: +1 425 672 0816 / Fax: +1 425 673 7647

Singapore MUSIC Group Services SG (Pte.) Ltd
 Tel.: +65 6845 1800 / Fax: +65 6214 0275
Australia MUSIC Group Services AU Pty Ltd
 Tel.: +61 03 9877 7170 / Fax: +61 03 9877 7870

Japan MUSIC Group Services JP K.K.
 Tel.: +81 3 5281 1180 / Fax: +81 3 5281 1181

TECHNICAL SPECIFICATIONS AND APPEARANCES ARE SUBJECT TO CHANGE WITHOUT NOTICE AND ACCURACY IS NOT GUARANTEED. BEHRINGER IS PART OF THE MUSIC GROUP (MUSIC-GROUP.COM). ALL TRADEMARKS ARE THE PROPERTY OF THEIR RESPECTIVE OWNERS. MUSIC GROUP ACCEPTS NO LIABILITY FOR ANY LOSS WHICH MAY BE SUFFERED BY ANY PERSON WHO RELIES EITHER WHOLLY OR IN PART UPON ANY DESCRIPTION, PHOTOGRAPH OR STATEMENT CONTAINED HEREIN. COLORS AND SPECIFICATIONS MAY VARY FROM ACTUAL PRODUCT. MUSIC GROUP PRODUCTS ARE SOLD THROUGH AUTHORIZED FULFILLERS AND RESELLERS ONLY. ALL RIGHTS RESERVED. © 2011 MUSIC Group IP Ltd. Trident Chambers, Wickhams Cay, P.O. Box 146, Road Town, Tortola, British Virgin Islands. 985-10000-00358