

## Large Format Mixers

# EURODESK SX3242FX

**U-PHONO—High-quality USB Audio Interface with Built-in Phono Preamp and Massive Software Package for Digitalizing Your Tapes and Vinyl Records**

- Premium ultra-low noise, high-headroom analog mixer
- 24 state-of-the-art XENYX Mic Preamps comparable to stand-alone boutique preamps
- Neo-classic “British” 3-band EQs with semi-parametric mid band for warm and musical sound
- 2 independent studio-grade 24-bit stereo FX processors with 99 awesome presets including reverb, chorus, flanger, delay, pitch shifter and various multi-effects
- High-precision 9-band stereo graphic EQ allows precise frequency correction of monitor or main mixes
- Revolutionary FBQ Feedback Detection system instantly reveals critical frequencies
- Peak LEDs, Mute, Main mix and subgroup routing switches, Solo and PFL functions on all channels
- 2 fully featured stereo input channels with 4-band EQ plus 2 additional stereo input channels with Level and pre-fader Aux controls
- Inserts on each mono channel and main mix for flexible connection of outboard equipment
- 4 Subgroup outputs and additional Mono output with sweepable Low Pass filter for subwoofer application
- 4 Aux sends per channel: 2 pre/post fader switchable for monitoring/FX applications, 2 post fader (for internal FX or as external send)



If you want classic analog handling but can't skimp on superior digital effects and studio-grade mic preamps, the SX3242FX is your new best friend. This mixer's 24 microphone inputs, 8 stereo inputs and 4 buses give you enough leeway to handle anything from a graduation speech to a 5-piece band to a whole church service with praise band and choir.

### Classic control, state-of-the-art sound

Each of the SX3242FX's 24 mic inputs connects to our world-famous, studio-grade XENYX mic preamps. They are legendary for their high headroom, warm natural timbre and utter lack of background noise. Plug in a large-diaphragm condenser mic and track a vocal to hear XENYX's rich detail and spaciousness. Plug in a dynamic mic and stick it inside a bass drum to appreciate the whopping headroom.

### You may experience side-FX...

Whether you need to add a dab of reverb or delay to a live vocalist's mic or warp a hard day's studio session into psychedelic quicksand, the SX3242FX has you covered. We gave this mixer two independent studio-grade 24-bit stereo FX processors with 99 awesome presets to provide the perfect sonic garnish. "Sure they're great for live sound, but I have a lot of cool plug-ins for recording," we can hear some of you saying. Truth be told, you never have too many effects. And when you hear the quality of the SX3242FX's FX, you may want to give your overworked CPU a rest.

Naturally we gave you a whole palette of creative effects like reverb, chorus, flanger, delay and pitch shifter tones, as well as mind-bending multi-effects to take your sound out of this world. But you also get problem solving workhorses like compression and gating plus final effects

*Continued on next page*

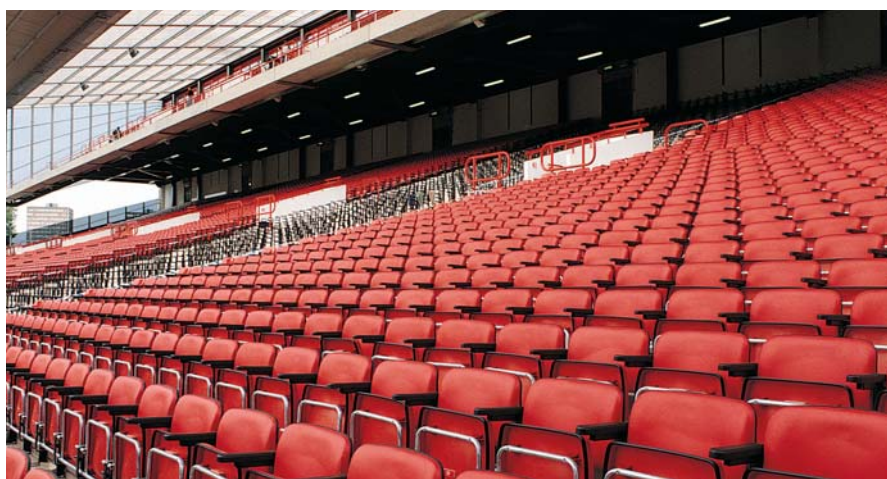

# EURODESK SX3242FX

- Balanced Main mix outputs with ¼" jack and gold-plated XLR connectors, separate Control room, Headphone and stereo Tape outputs
- Solo-In-Place and Pre-Fader-Listen functions plus full-featured Talkback section
- Standby switch mutes all channels during breaks while background music is provided via CD/Tape inputs
- Long-wearing 60 mm logarithmic-taper faders and sealed rotary controls
- Internal autorange power supply for maximum flexibility (100 – 240 V~), noise-free audio, superior transient response plus low power consumption for energy saving
- High-quality components and exceptionally rugged construction ensure long life
- Conceived and designed by BEHRINGER Germany

such as Ultramizer, Ultrabass and Exciter that can put a PA or studio mix over the top. And because there are two processors, you can cue two separate effects, then apply one or both to channels 1 through 28 — compression for the vocalist, reverb for the vocalist and snare drum, for example.

## What the heck is "British EQ"?

A good thing to have on your side when you start reaching for those channel equalization knobs. At a live concert or in the studio.

Think of it as kinder, gentler, more musical EQ like the type found on classic British consoles from the 60's and 70's. Single malt scotch instead of Everclear. Home-baked cherry cobbler instead of an artificial cherry lollypop.

British EQ's distinct configuration of wider curves/lower Q and harmonic phase characteristics allows you to add or subtract EQ more generously than you can with conventional EQ circuit designs. When you add low midrange, you get a firmer sound instead of a nasty bonk. When you back high frequencies off a bit, treble backs off just a hair instead of turning muffled.

All SX3242FX mono channels have low and high shelving plus a sweepable "midrange" you can move anywhere from 100Hz to 8kHz. Think of it as your roving English troubleshooter.

## Kill feedback before it maims your audience.

When it comes to suppressing feedback, the SX3242FX is like having a bloodhound trained to spot trouble frequencies a mile away.

The 9-band graphic EQ (which you can choose to apply to your main mix or monitor mix via the MAIN/AUX1 button) features the FBQ Feedback Detection system. It makes finding and adjusting critical frequencies a snap. Just push FBQ IN, then watch as LEDs on the individual EQ sliders light up, indicating which frequency bands are causing feedback. Simply adjust until the LED goes dim.

## The Ins and Outs

Some manufacturers make what they call 32-input mixers that count stuff like CD/TAPE IN as an input. But the SX3242FX really gives you twenty-four honest mono channels plus eight stereo channels, making it easy to accommodate a variety of studio or live performance configurations. You can connect up to 24 microphones or other mono instruments and up to four stereo instruments (keyboards or tone modules, for example).

You can combine these input in four different sub-mixes (we call them buses). That allows you to blend multiple channels—say all the mics on a drum kit or all the backup singers' mics—to a single fader, which is easier to adjust for the overall mix that goes to the PA speakers. You can also use one or more of the sub-mix buses to create custom monitor mixes for picky members of your band ("More me! More me!").

## A zillion ways to change the channel

At the top of each mono channel, you'll find both a balanced XLR input with a XENYX mic preamp and a ¼" input. A phantom power switch located on the back near the main power switch accommodates condenser mics.

*Continued on next page*



# EURODESK SX3242FX

## Effects

### PARALLEL EFFECTS:

Cathedral (01-02)	Very dense and long reverberation of a large cathedral
Plate (03-04)	Simulates early plate reverb
Concert (05-06)	Simulates a small theater or large concert hall
Stage (07-08)	Very dense reverb, especially for live applications
Room (09-10)	Simulates room's wall reverb. This particular room has two windows and yellow wallpaper
Studio (11-12)	Adds spaciousness to the sound
Small Hall (13-14)	Simulates hallway reverberation
Ambience (15-16)	Simulates the reverb of a middle-sized room without late reflections
Early Reflections (17)	Dense reverb with pronounced early reflections
Spring Reverb (19-20)	Simulates spring reverb
Gated Reverb (21-22)	Reverb that's synthetically cut off
Reverse Reverb (23-24)	Reverb that slowly gets louder
Chorus (25-30)	Slight detuning of the original signal
Flanger (31-35)	A delayed signal is added to the original signal, causing a phase shift
Phaser (36-39)	Another phase-shift effect
Rotary Speaker (40-42)	Simulation of a rotating electronic organ speaker
Delay (43-52)	Delay of the input signal with repetitions
Chorus & Reverb (53-54)	Combination of chorus and reverb
Flanger & Reverb (55-56)	Flanger combined with reverb
Phaser & Reverb (57-58)	Phaser combined with reverb
Rotary Speaker & Reverb (59-60)	Rotary Speaker effect combined with Reverb
Delay & Reverb (61-63)	Delay combined with Reverb
Delay & Chorus (64-67)	Widens the signals and produces repetition effects
Delay & Flanger (68-70)	Similar to Delay & Chorus, but with audible up/downward modulation

### INSERT EFFECTS:

Compressor (71-73)	Soft or loud passages are raised or lowered in level respectively
Expander (74-76)	Noise and hum is reduced in level
Gate (77-78)	A gate opens for a specific period of time to make a specific signal pass, then closes abruptly
Ultramizer (79-80)	Compression through automatic adaptation of compression parameters
Ultrabass (81-82)	Combines sub-harmonics processor, bass exciter, and limiter
Panner (83-85)	The signal "wanders" between the sides of the stereo basis
Exciter (86-88)	Adds synthetic harmonics to the signal, resulting in increased presence and "loudness"
Auto Filter (89-91)	Level-dependent boost of a specific frequency band, similar to auto-wah or electric guitars
Tube Distortion (92-93)	Simulates the tube distortion of classic guitar amplifiers
Guitar Amp (94-97)	Guitar amp simulation
Vinylizer (98)	Adds the clicks and noise of old vinyl records
Test Tone (99)	1-kHz test tone. Virtually indistinguishable from some genres of techno.

Next comes is an insert for connecting up individual signal processors or feeding a remote broadcast feed or multitrack recorder directly.

Trim control and level set LED let you adjust the channel's input level for maximum headroom and minimum noise — the huge range of this control can handle anything from a very timid vocalist to a close-miked guitar amp stack.

Each mono channel features a 3-band EQ with semi-parametric mids (giving you control of the Mid level and a sweepable frequency with a boost or cut of 15 dB) and a Trim control for adjusting input gain via a Level Set LED.

A Low Cut button eliminates the frequencies where unwanted infrasonics such as mic handling, P-pops or wind noise occur.

FX1 and FX2 dials add a blend of up to two effects, and AUX1 and AUX2 dials help create your monitor mix. Press the PRE button to send a raw, EQ-free signal to the monitors.

Near every mono channel's fader you'll find a 1-2, 3-4 and MAIN button. By engaging the MAIN button, the signal is sent to the main mix. Or, if you engage the 1-2 button, the channel becomes part of a bus. Twist the PAN control all the way to the left to assign it to Sub 1, or all the way to the right for Sub 2. The same principle applies to the 3-4 button.

A Mute button with accompanying LED cuts the signal from the channel, and a Clip LED helps you dial in a distortion-free post-EQ signal. The Solo button on individual channels routes the subgroup signal to the solo bus or Pre-Fader Listen—depending on whether the signal has been included in a subgroup.

Instead of XLR inputs, stereo channels 25-32 have left and right balanced/unbalanced line level inputs. Channels 25-28 feature the same controls as the mono channels, but with a four-band EQ that gives you control of HIGH, HIGH MID, LOW MID and LOW. This is especially useful for EQ'ing the critical midrange frequency content found in keyboard signals.

Stereo channels 29 through 32, designed for signals that do not require EQ, have a simplified interface consisting of a Level, AUX1 and AUX2 dial. Can you say laptop backing track feeds, drum machines, tone modules, DJ mixers or CD players?

Finally, all four sub-mix buses feature an independent fader (naturally), Solo switch with bright LED, and assign buttons for routing them to Left or Right stereo channels.

### Packed with tasty details that make your creative life easier.

- We solved the problem of what to do when you want to play music during breaks but don't want to have to mute every channel or turn down every fader. Just push CD/Tape STANDBY button to A) mute all mixer channels and B) solo just your CD/Tape source.
- We didn't just give you a MONO output for subwoofers. We gave it a built-in variable low pass crossover, saving you money on outboard gear.
- We added a footswitch jack that you can use to control either internal or external effects.
- We gave you a complete Phones and Control Room assignment matrix so you can send mains, buses, CD/Tape or auxes out at the touch of a button.
- We added a routing button to Talkback so you can talk directly to either a monitor mix or the house mix for public announcements.
- We made the 9-band equalizer assignable to either AUX 1 or the main mix.

### Take On The World

Not every town on the planet uses the same voltage common in yours. Unfortunately, this sometimes doesn't occur to jet-setting sound technicians until they're 5,000 miles from home. With the SX3242FX, this is never an issue. The internal autorange power supply can run on anything from 100 to 240 V with noise-free audio, top-quality transient response and low power consumption.

*Continued on next page*

# EURODESK SX3242FX

**Buy it now. Teach your great grandkids how to run it.**

BEHRINGER mixers last and last. We use top quality parts such as long-wear faders, sealed rotary controls and premium circuit boards. We have 20 years of experience figuring out how to compensate for clumsy load-ins, spilled drinks, crazed guitarists and millions of road miles. The result is a mixer you can count on day after day and night after night.

**Why do you need this mixer?**

- Built-in pristine XENYX mic preamps... LOTS of them
- Dual 24-bit FX processor with 99 presets including reverb, chorus, flanger, delay and pitch shifter tones
- British-style EQ dials give you the sound and control preferred by top studio engineers
- The built-in FBQ Feedback Detection system instantly reveals critical frequencies and the 9-band stereo graphic EQ allows precise correction of those frequencies in monitor or main mixes

- Awesomely complete I/O – everything from bus inserts to mono output

**Finally, "And now for something completely similar."**

If you've read this product sheet and loved everything about the SX3242FX except it seemed like a bit too much mixer for your current needs, we have good news for you. It has a little brother, the SX2442! Sixteen mono channels each with superb XENYX mic preamps. And of course every other feature you've just read about. But in a smaller form factor and lower price. See both models at your BEHRINGER Dealer today.

## Studio Set-Up

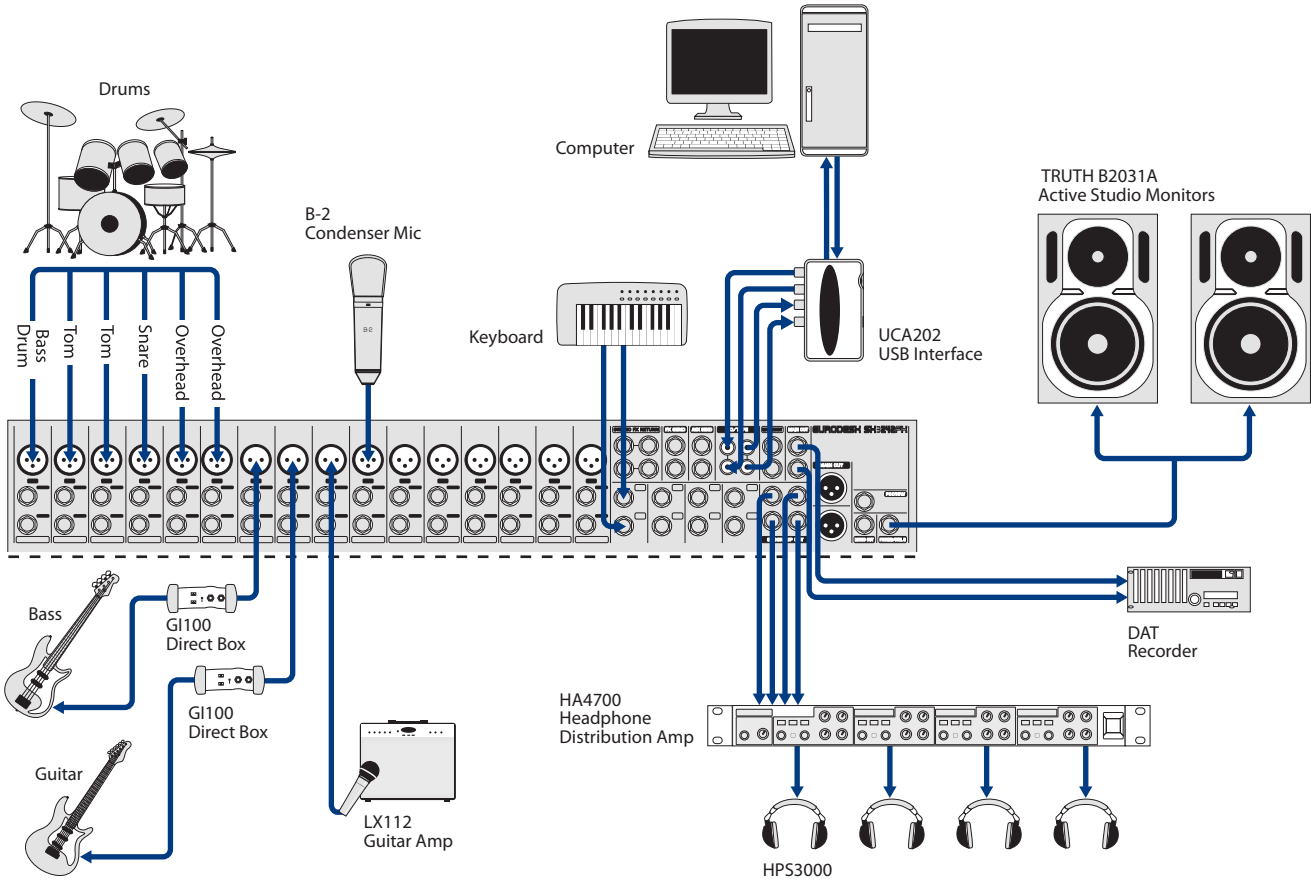

# EURODESK SX3242FX

## Live Set-Up

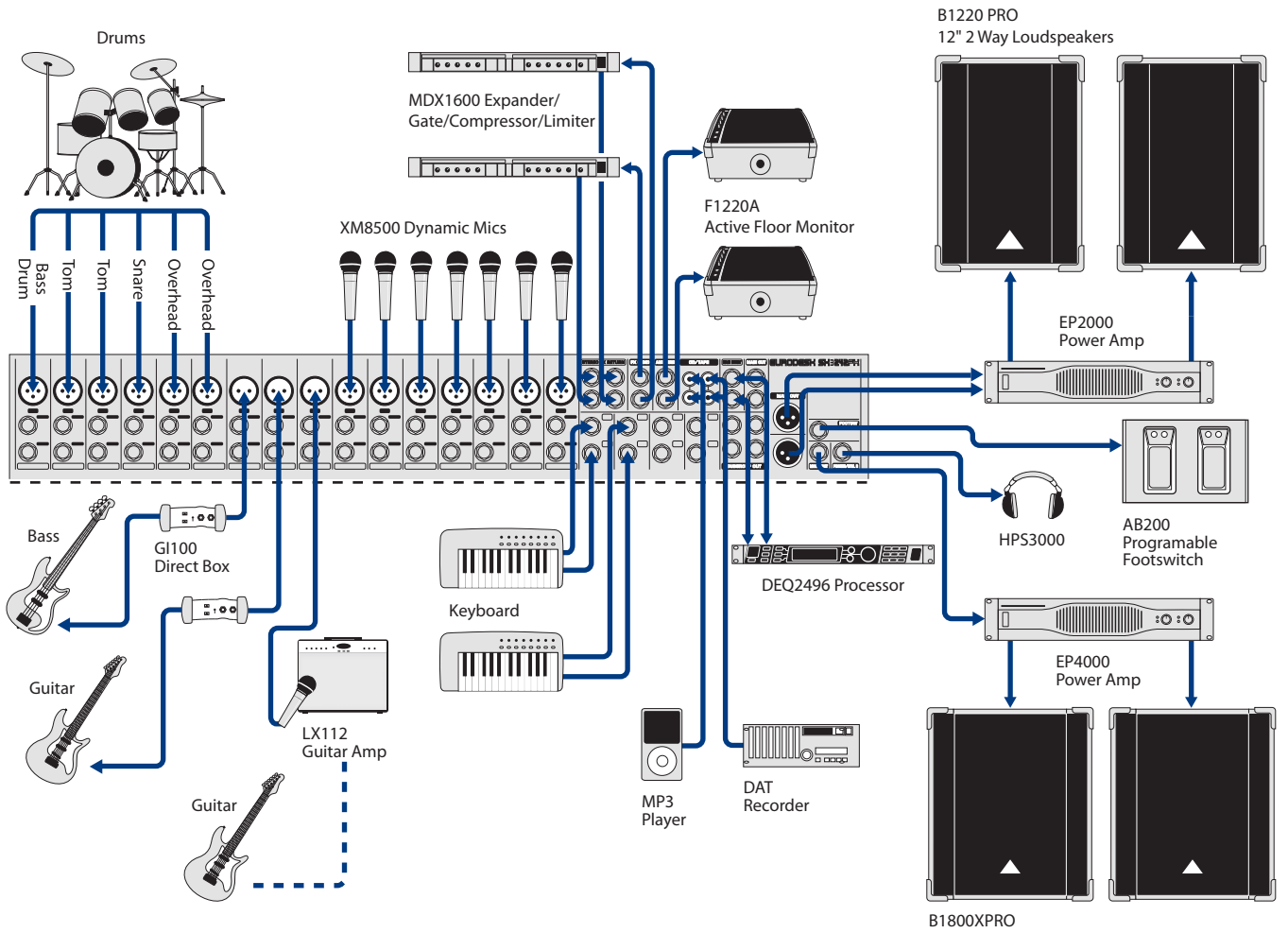

# EURODESK SX3242FX

SIXTEEN MONO channels, each with balanced XLR in with XENYX mic preamp and phantom power for condenser mics

1/4" TRS balanced/unbalanced input

Insert I/O for signal processing on individual channels (pre-fader, pre-EQ and pre-aux send)

LOW CUT filter (mono channels) eliminates unwanted infrasonics

Semi-parametric MID EQ is sweepable from 100Hz to 8KHz

AUX 1 & 2 level controls with PRE/post switch

FX1 and FX2 inject built-in FX into the channel or can be used to control an FX effects unit

MUTE switch (with bright LED) also mutes aux buses set to post-fader

SOLO routes the subgroup signal to the solo bus (Solo In Place) or PFL bus (Pre Fader Listen)

Silky-smooth 60mm faders on all channels and buses

The Stereo FX RETURN inputs return effect signals from external effects processors

EIGHT LINE IN-ONLY CHANNELS. Left and right balanced/unbalanced line level 1/4" TRS inputs (stereo channels 25-26, 27-28, 29-30 and 31-32)

TRIM control adjusts input gain via Level Set LED

12 kHz shelving HIGH EQ

80Hz shelving LOW EQ

PAN control sets position of the channel signal in the stereo mix

Channel CLIP LED

Routing switches for assigning channel to MAIN or Subgroups

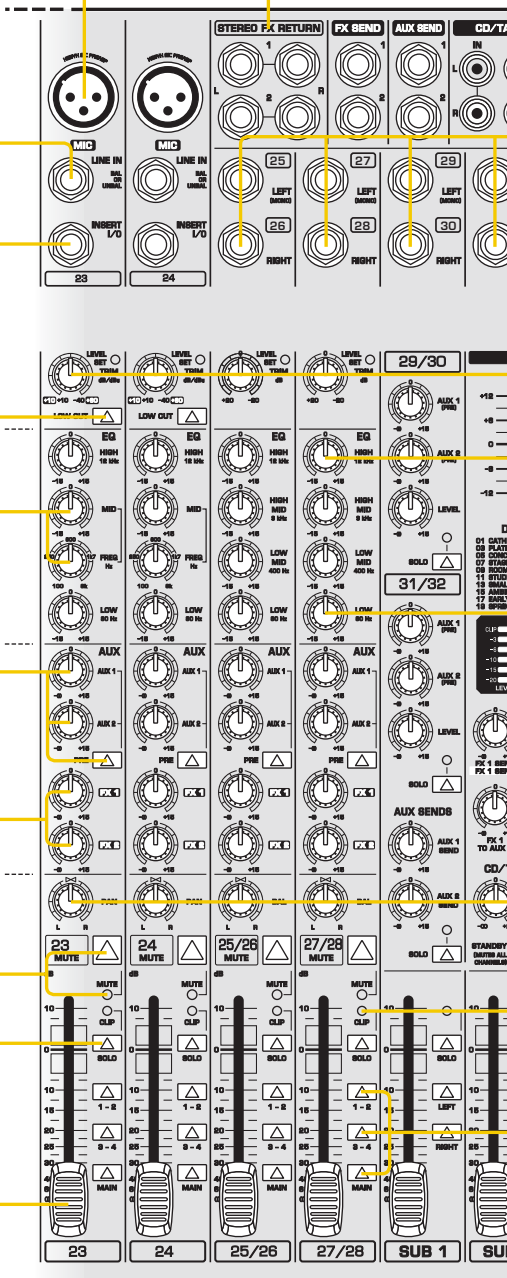

# EURODESK SX3242FX

Gold-plated CD/TAPE OUTPUT RCA connectors for output to USB interface/hard disk recorder or DAT

Gold-plated CD/TAPE INPUT RCA connectors for connecting MP3 or CD players or other line-level sources

MAIN INSERTS can be used to connect a dynamics processor or equalizer for further processing of the mix signal

FX SEND 1 and 2 can be routed to an external effects device

Master AUX SENDS 1 & 2 to external effects devices or monitor speakers

The MONO Out. Perfect for a subwoofer output

SUBGROUP outputs

9-band stereo equalizer. Use to adapt the sound to room acoustics or with the FBQ system

MAIN/AUX 1 switch selects source of the signal to be processed by the FX section

99 24-bit studio-quality digital effects including reverbs, delays, gates, phasers etc

Master FX 1 & 2 SEND controls

FX 1 & 2 effects level and selection controls

CD/TAPE level control. Between sets press STANDBY to mute all active channels except the music you're playing through the CD/TAPE input — so you don't have to change the levels of any channel faders!

60mm SUBmix bus faders 1, 2, 3 & 4. Each as a solo switch and switch to assign them to master Left or Right stereo channels

Balanced/unbalanced 1/4" TRS MAIN outputs

Balanced XLR MAIN outputs

FOOTSW (ITCH) jack for enabling/disabling FX 1 or FX 2 effects processors

1/4" TRS PHONES/CTRL ROOM OUT connector

FBQ Feedback Detection System Frequencies causing feedback are indicated by the brightly-lit fader LEDs

Graphic EQ IN / out

FX LED level meters for optimizing input signal level to digital effects

Switches assign internal effects to MAIN bus or subgroups 1-2 or 3-4

11-LED master level meter

The SOLO/PFL switch determines whether the monitored signal is pre- or post-fader

TALKBACK level control (can also be assigned to AUX 1/2)

MONO output frequency control and separate LOW PASS filter

PHONES/CONTROL ROOM level control and assignment switches

60mm mono out and main stereo out faders

# EURODESK SX3242FX

## MONO INPUTS

### Microphone inputs (XENYX Mic preamp)

Type	XLR connector, electronically balanced, discrete input circuit
------	--

### Mic E.I.N. 1 (20 Hz – 20 kHz)

@ 0 $\Omega$ source resistance	-134 dB/135.7 dB A-weighted
@ 50 $\Omega$ source resistance	-131 dB/133.3 dB A-weighted
@ 150 $\Omega$ source resistance	-129 dB/130.5 dB A-weighted

### Frequency response

<10 Hz-160 kHz	-1 dB
<10 Hz-200 kHz	-3 dB
Gain range	+10 dB to +60 dB
Max. input level	+12 dBu @ +10 dB GAIN
Impedance	approx. 2.6k $\Omega$ balanced
Signal-to-noise ratio (0 dBu In @+22 dB GAIN)	110 dB/112 dB A-weighted
Distortion (THD+N)	0.005%/0.004% A-weighted

### Line input

Type	¼" TRS jack, electronically balanced
Impedance	approx. 20 k $\Omega$ balanced, approx. 10 k $\Omega$ unbalanced
Gain range	-10 dB to +40 dB
Max. input level	+22 dBu @ 0 dB GAIN

### Fade-out attenuation<sup>2</sup> (Crosstalk attenuation)

Main fader closed	90 dB
Channel muted	84 dB
Channel fader muted	85 dB
Frequency response (Mic In → Main Out)	
<10 Hz – 90 kHz	+0 dB/-1 dB
<10 Hz – 160 kHz	+0 dB/-3 dB

### Stereo Inputs

Type	2 x ¼" TRS jack, balanced
Impedance	approx. 20 k $\Omega$ balanced, 10 k $\Omega$ Unbalanced
Gain range	-20 dB to +20 dB
Max. input level	+22 dBu @ 0 dB GAIN

### CD/Tape in

Type	RCA Connector
Impedance	approx. 10 k $\Omega$
Max. input level	+22 dBu

## EQUALIZER

### EQ mono channels

LOW	80 Hz/±15 dB
MID	100 Hz to 8 kHz/±15 dB
HIGH	12 kHz/15± dB
LOW CUT	80Hz, 18 dB/oct.

### EQ stereo channels

LOW	80 Hz/±15 dB
LOW MID	500 Hz/±15 dB
HIGH MID	3 kHz/±15 dB
HIGH	12kHz/±15 dB

### Channel inserts

Type	¼" TRS jack, unbalanced
Max. input level	+22 dBu

### AUX/FX Send

Type	¼" mono jack, unbalanced
Impedance	approx. 120 $\Omega$
Max. output level	+22 dBu

### FX Returns

Type	¼" mono jack, unbalanced
Impedance	approx. 10 k $\Omega$
Max. input level	+22 dBu

### Subgroup outputs

Type	¼" mono jack, unbalanced
Impedance	approx. 120 $\Omega$
Max. output level	+22 dBu

### Main outputs (XLR)

Type	XLR connector, electronically balanced
Impedance	approx. 240 $\Omega$ balanced, 120 $\Omega$ unbalanced
Max. output level	+28 dBu

### Main outputs (¼")

Type	¼" TRS jack, electronically balanced
Impedance	approx. 240 $\Omega$ balanced, 120 $\Omega$ unbalanced
Max. output level	+28 dBu

### Main Inserts

Type	¼" TRS jack, unbalanced
Max. input level	+22 dBu

## Mono output

Type	¼" mono jack, unbalanced
Impedance	approx. 120 $\Omega$
Max. output level	+22 dBu
Low pass	variable, 30 Hz to 200 Hz, 18 dB/oct.

### Phones/CTRL room output

Type	¼" TRS jack, unbalanced
Max. output level	+19 dBu/150 $\Omega$ (+25 dBm)

### CD/Tape Out

Type	RCA connector
Impedance	approx. 1 k $\Omega$
Max. output level	+22 dBu

### DSP

Type	Texas Instruments
Converter	24-bit delta-sigma, 64/128-times oversampling
Sampling rate	46 kHz

### Main mix system data<sup>3</sup>(Noise)

Main mix @ - $\infty$ , channel fader @ - $\infty$	-100 dB/-102.5 dB A-weighted
Main mix @ 0 dB, channel fader @ - $\infty$	-82 dB/-85 dB A-weighted
Main mix @ 0 dB, channel fader @ 0 dB	-72 dB/-75 dB A-weighted

### Power supply

Power consumption	50 W
Fuse	(100 – 240 V~, 50/60 Hz) T 2,0 A H 250 V
Mains connector	Standard IEC receptacle

### Physical/weight

Dimensions (H x W x D)	3.9 x 35.3 x 16.1"/100 x 896 x 410 mm
Weight (net)	24.3 lbs/11.0 kg

1 Equivalent Input Noise

2 Measuring conditions: 1 kHz rel. to 0 dBu; 20 Hz – 20 kHz; line input; main output; unity gain

3 20 Hz – 20 kHz; measured at main output. Channels 1 – 4 unity gain; EQ flat; all channels on main mix; channels 1/3 as far left as possible; channels 2/4 as far right as possible; reference = +6 dBu.

Please note these specifications are preliminary and conceptual in nature, and as such are subject to change as product development progresses. This information is supplied for market research purposes only and is not to be made public in any manner. This document is solely the property of The MUSIC Group, or one of its subsidiaries, and must be surrendered upon request of the owner.

For service, support or more information contact the BEHRINGER location nearest you:

**Europe** Tel.: +49 2154 9206 4149  
Fax: +49 2154 9206 4199

**USA/Canada** Tel.: +1 425 672 0816  
Fax: +1 425 673 7647

**Singapore** Tel.: +65 6845 1800  
Fax: +65 6214 0275

**Australia** Tel.: +61 03 9877 7170  
Fax: +61 03 9877 7870

**Japan** Tel.: +81 3 5281 1180  
Fax: +81 3 5281 1181

©2011 Red Chip Company Ltd. Technical specifications and appearance subject to change without notice. The information contained herein is correct at the time of printing. All trademarks are the property of their respective owners. BEHRINGER accepts no liability for any loss which may be suffered by any person who relies either wholly or in part upon any description, photograph or statement contained herein. 985-10000-00283

behringer.com

