

## Rackmount Mixers

# EURORACK PRO RX1202FX



### EURORACK PRO Ultra Low-Noise Design 12-Input 2-bus Mic/Line Rack Mixer with Premium Mic Preamplifiers and 24-Bit Multi-FX Processor

- Ultra-low noise ULN design, highest possible headroom, ultra-transparent audio
- 8 new state-of-the-art, studio-grade IMP "Invisible" Mic Preamps with:
- 130 dB dynamic range for 24-bit, 192 kHz sampling rate inputs
- Ultra-wide 60 dB gain range
- Integrated 24-bit digital stereo FX processor with 100 awesome presets including reverb, chorus, flanger, delay, pitch shifter and various multi-effects
- Effective, extremely musical 2-band EQ and Clip LED on all channels
- 4 balanced high-headroom line inputs
- State-of-the-art 4580 operational amplifiers provide lowest noise and distortion—better than 4560 op amps
- 2 aux sends per channel: 1 pre fader for monitoring applications, 1 post fader for internal FX or as external send
- CD/tape inputs assignable to main mix or control room/phones outputs
- Separate control room, phones and stereo CD/tape outputs

Looking for a versatile line/mic mixer that fits in a rack AND eliminates the need for tons of outboard gear? The 12-channel RX1202FX is not only rack mountable, but comes loaded with a 24-bit multi-FX processor and 8 built-in studio-grade IMP "invisible" mic preamps. This mixer works perfectly for small bands or churches, business conferences with both microphone and A/V equipment as well as sub-mixing keyboards, drums, samplers or multiple vocal mics. It's also the ideal choice for monitoring multi-track recording projects.

#### Channel some serious mojo

Sometimes you feel like a mic...or a sampler...or a drum machine. Sometimes you don't. Whatever the situation calls for, the RX1202FX is ready to accommodate. Each mono channel (1-8) features an XLR input, a balanced 1/4" mono input and an INSERT jack for patching external signal processors directly into the channel.

Mono channels feature a TRIM control and CLIP LED to adjust the input gain; a two-band EQ (HIGH, MID and LOW

controls); FX control to determine how much of an effect to apply to the channel; a PAN control; and a smooth 60 mm fader to determine the channel's level in the mix.

Stereo channels (9-12) feature left and right balanced line level 1/4" inputs and the same front panel control as their mono counterparts. And, as mentioned above, they can be used as mono inputs themselves.

#### Taking control

Smooth 60 mm faders and intuitive rotary dials make it quick and simple to create a killer mix. The MAIN MIX fader adjusts the volume of the main output signal while the dual 4-segment LED ladder display gives a visual representation of the signal level. The PHONES jack features a dedicated PHONES/CONTROL ROOM dial for adjusting headphone volume. Push CD/TAPE TO MIX to add backing tracks from an MP3 or CD player, or to isolate a click track or scratch track in headphones while recording.

*Continued on next page*



# EURORACK PRO RX1202FX

- Balanced main mix outputs with gold-plated XLR connectors
- Switchable +48 V phantom power for condenser microphones
- Long-wearing 60 mm logarithmic-taper faders and sealed rotary controls
- Internal switch-mode power supply for maximum flexibility (100 – 240 V~), noise-free audio, superior transient response plus lowest possible power consumption for energy saving
- High-quality components and exceptionally rugged construction ensure long life
- Conceived and designed by BEHRINGER Germany

On the back panel, the LEFT and RIGHT MAIN OUT XLR jacks can be used to feed a recording device or PA system. For live performances, keep pre-recorded music cued up for between-set breaks by connecting a CD player or MP3 player via the stereo CD/TAPE IN jacks. If the band wants a recording of their performance, send signal to a recording device such as a mini-disc recorder via the CD/TAPE OUT jacks. Use the MON AUX SEND to send signal to floor monitors in a live setting, or to a headphone amp in a recording setting. When it's time for playback of recorded material, send signal to studio monitors through the CTRL OUT jack.

If a recording session or live performance calls for an effect not programmed in the onboard FX processor, send signal to an outboard effects unit via the FX AUX SEND, then feed the signal back to the RX1202 through the AUX RETURN jacks.

### Effects, effortlessly

The FX/CTRL section puts sophisticated digital effects at your fingertips. Use the PROGRAM dial to scroll through the effect presets, then use the FX TO MAIN dial to govern how much of the effect is heard in the summed signal of the mixer. Push FX SOLO to hear only the effects signal in your monitors or headphones.

*Continued on page 4*

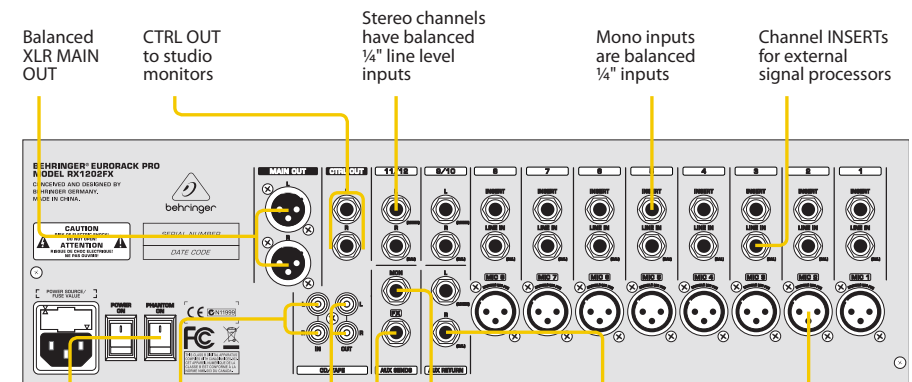
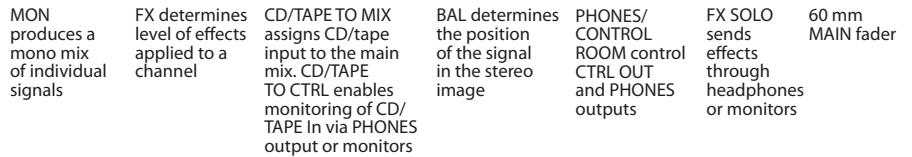
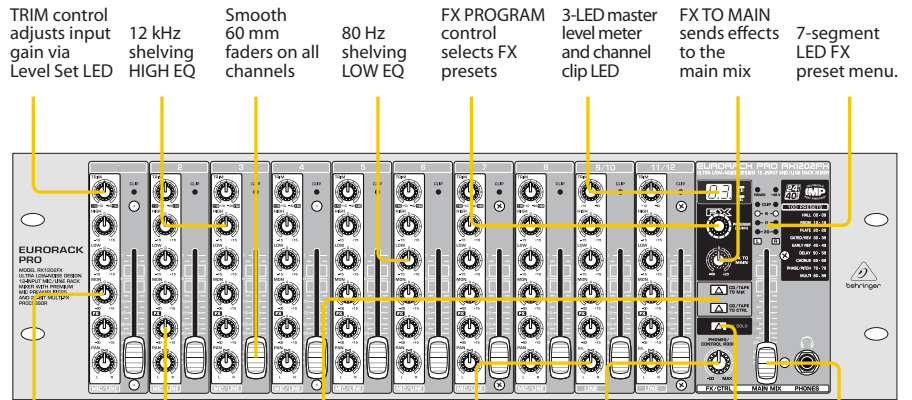

# EURORACK PRO RX1202FX

## Recording Studio

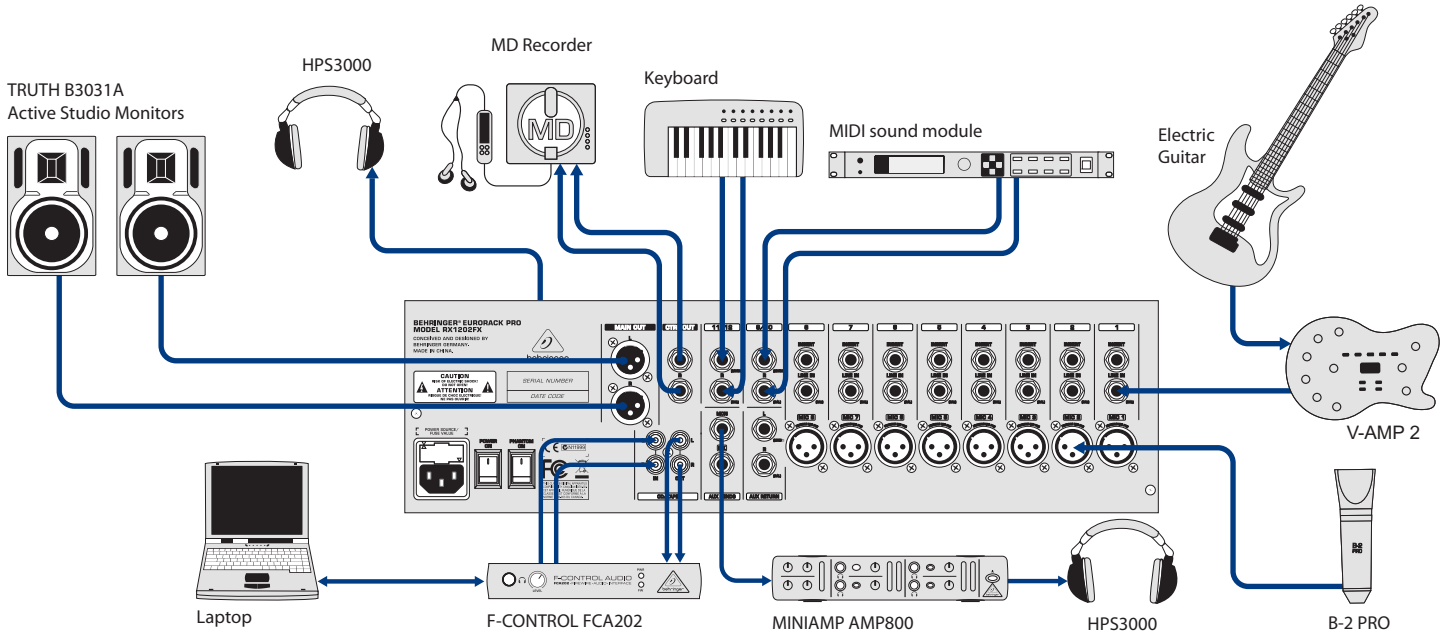

## Live Sound

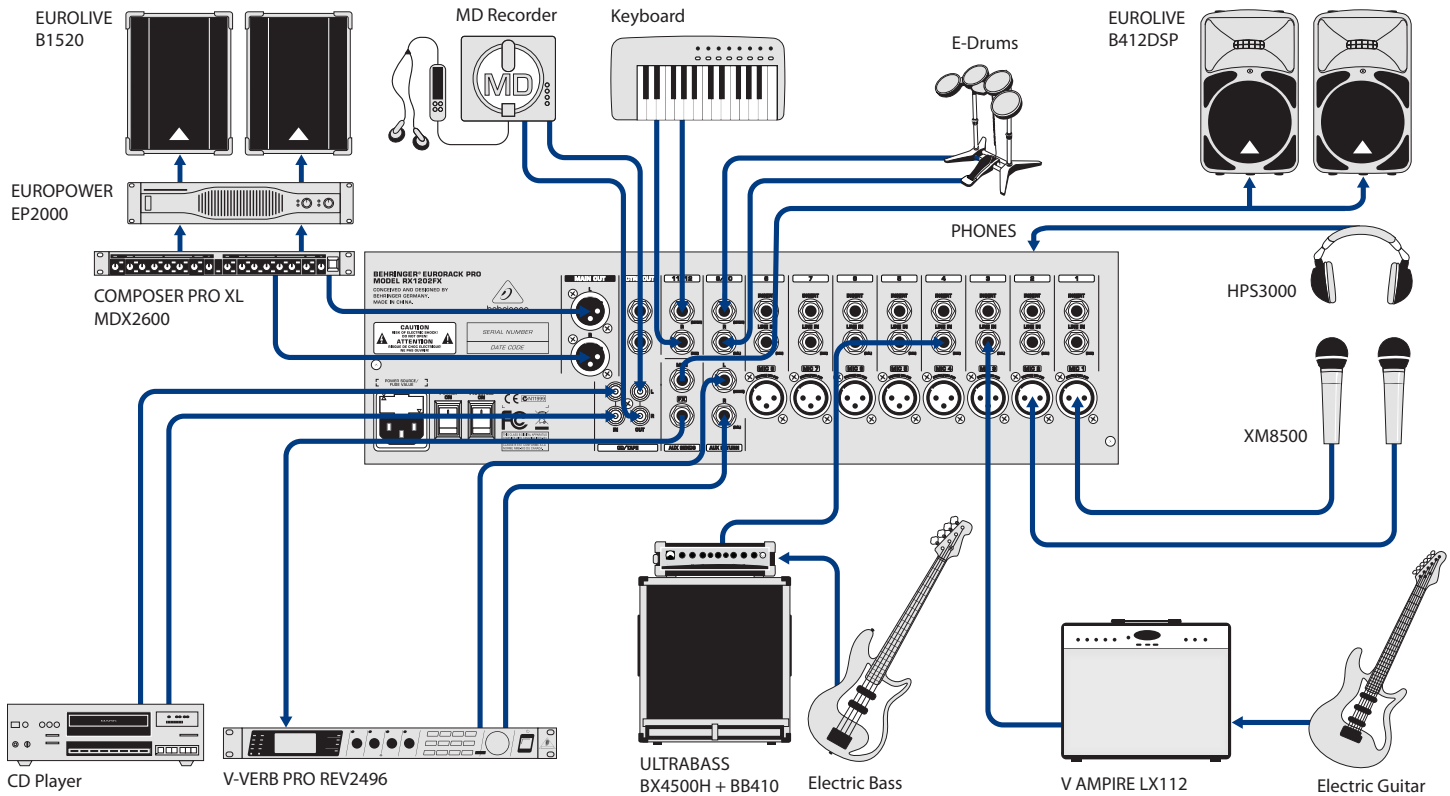

# EURORACK PRO RX1202FX

## Superior sound, unparalleled value

It's nearly impossible to find a rack-mountable mixer loaded with the inputs, mic preamps and digital effects found in the RX1202FX. And with a price tag that's well below what you would pay to purchase all these tools separately, the RX1202FX is the smartest way to make your studio, live band, church or conference sound like a million bucks.

## RX1202FX PRESETS

HALL (Reverb)	00 – 09
ROOM (Reverb)	10 – 19
PLATE (Reverb)	20 – 29
GATED/REV (Reverb)	30 – 39
EARLY REF	40 – 49
DELAY	50 – 59
CHORUS	60 – 69
PHASE/PITCH	70 – 79
MULTI	80 – 99

## MONO INPUTS

### MIC (IMP Invisible Mic Preamp)

Type	XLR, electr. Balanced
Mic E.I.N.	(20 Hz — 20 kHz)
@ 0 Ω source resistance	-132 dB / -134 dB A-weighted
@ 50 Ω source resistance	-130 dB / -132 dB A-weighted
@ 150 Ω source resistance	-128 dB / -130 dB A-weighted
Frequency response	<10 Hz — 200 kHz
Gain range	+10 to +60 dB
Max. input level	+12 dBu @ +10 dB gain
Impedance	approx. 2.6 kΩ balanced
Signal-to-noise ratio	-110 dB / -112 dB A-weighted
Distortion (THD+N)	0.003%, A-weighted

### LINE IN

Type	¼" TRS connector, Electronically balanced
Impedance	approx. 20 kΩ balanced 10 kΩ balanced
Gain range	-10 dB to +40 dB
Max. input level	+22 dBu @ 0 dB gain

### STEREO INPUTS

Type	¼" TRS connector, Electronically balanced
Impedance	approx. 20 kΩ balanced 10 kΩ unbalanced
Max. input level	+22 dBu

### INSERT

Type	¼" TRS connector (Tip=Send, Ring=Return)
------	---

### AUXILIARY INPUTS

#### CD/TAPE IN

Type	RCA connectors, unbalanced
Impedance	approx. 20 kΩ
Max. input level	+22 dBu

#### AUX RETURN

Type	¼" TRS connector, balanced
Impedance	approx. 20 kΩ balanced 10 kΩ unbalanced
Max. input level	+22 dBu

## OUTPUTS

### AUX SENDS (FX)

Type	¼" TRS connector, impedance Balanced
Impedance	approx. 240 Ω unbalanced 120 Ω unbalanced
Max. output level	+22 dBu

### AUX SENDS (MON)

Type	¼" TRS connector, impedance balanced
Impedance	approx. 240 Ω balanced 120 Ω unbalanced
Max. output level	+22 dBu

### MAIN OUT

Type	XLR connectors, balanced
Impedance	approx. 240 Ω balanced 120 Ω unbalanced
Max. output level	+28 dBu balanced +22 dBu unbalanced

### CTRL OUT

Type	¼" TRS connector, impedance balanced
Impedance	approx. 240 Ω balanced 120 Ω unbalanced
Max. output level	+22 dBu

### CD/TAPE OUT

Type	RCA connectors, unbalanced
Impedance	approx. 1Ω
Max. output level	+22 dBu

### PHONES

Type	¼" TRS connector
Max. output level	+19 dBu / 150 Ω (316 mW)

### EQ

Low	100 Hz / ±15 dB
High	12 kHz / ±15 dB

### MAIN MIX SYSTEM DATA<sup>1</sup>

#### Noise

Main mix @ -∞, Channel fader -∞	-98 dB / -101 dB A-weighted
Main mix @ 0 dB Channel fader -∞	-85 dB / -88 dB A-weighted
Main mix @ 0 dB, Channel fader @ 0 dB	-77 dB / -80 dB A-weighted

## Fade attenuation<sup>2</sup> (Crosstalk attenuation)

Main fader closed	90 dB
Channel fader closed	90 dB

## Frequency response

Microphone input to Main Out	<20 Hz — 105 kHz +1 dB / -1 dB <10 Hz — 170 kHz +3 dB / -3 dB
---------------------------------	--

## EFFECTS SECTION

Converter	24-bit Sigma-Delta
Frequency rate	40 kHz
Presets	100

## POWER SUPPLY

Power consumption	18 W
Voltage	100 — 240 V~, 50/60 Hz
Fuse	100 — 240 V~: T 1.6 A H 250 V
Mains connection	IEC (power) cable

## DIMENSIONS/WEIGHT

Dimensions (H x W x D)	approx. 5 1/5 x 19 x 5 9/10" approx. 133 x 482 x 150 mm
Weight (net)	approx. 6.4 lbs/2.9 kg

### Measuring conditions:

<sup>1</sup> 20 Hz — 20 kHz; measured at main output. Channels 1—8 gain @ unity; EQ flat; all channels on main mix; channels 1/3/5/7 leftmost, channels 2/4/6/8 rightmost. Reference = +6 dBu.

<sup>2</sup> 1 kHz relative to 0 dBu; 20 Hz—20 kHz; line input; main output; gain @ unity.

Please note these specifications are preliminary and conceptual in nature, and as such are subject to change as product development progresses. This information is supplied for market research purposes only and is not to be made public in any manner. This document is solely the property of The MUSIC Group, or one of its subsidiaries, and must be surrendered upon request of the owner.

For service, support or more information contact the BEHRINGER location nearest you:

**Europe** Tel.: +49 2154 9206 4149  
Fax: +49 2154 9206 4199

**USA/Canada** Tel.: +1 425 672 0816  
Fax: +1 425 673 7647

**Singapore** Tel.: +65 6845 1800  
Fax: +65 6214 0275

**Australia** Tel.: +61 03 9877 7170  
Fax: +61 03 9877 7870

**Japan** Tel.: +81 3 5281 1180  
Fax: +81 3 5281 1181

©2011 Red Chip Company Ltd. Technical specifications and appearance subject to change without notice. The information contained herein is correct at the time of printing. All trademarks are the property of their respective owners. BEHRINGER accepts no liability for any loss which may be suffered by any person who relies either wholly or in part upon any description, photograph or statement contained herein. 985-10000-00349

behringer.com

