

## Technical Specifications



# ULTRALINK PRO MX882

Ultra-Flexible 8-Channel Splitter/Mixer

# EN ULTRALINK PRO MX882

## Ultra-Flexible 8-Channel Splitter/Mixer

- Ultra-low noise 8 in/2 out line mixer and 2 in/8 out line splitter
- Each channel can operate independently in mixer or splitter mode
- Usable as 6 in/6 out level matching amplifier or direct injection box
- Converts levels between -10 dBV and +4 dBu
- Extremely wide bandwidth from 5 Hz to 200 kHz for highest signal integrity
- 6 mono in, 6 mono out, 2 main inputs and 2 outputs
- 4/8-segment input/output level meters for all channels
- High-quality components and exceptionally rugged construction ensure long life
- Conceived and designed by BEHRINGER Germany

## Block Diagram

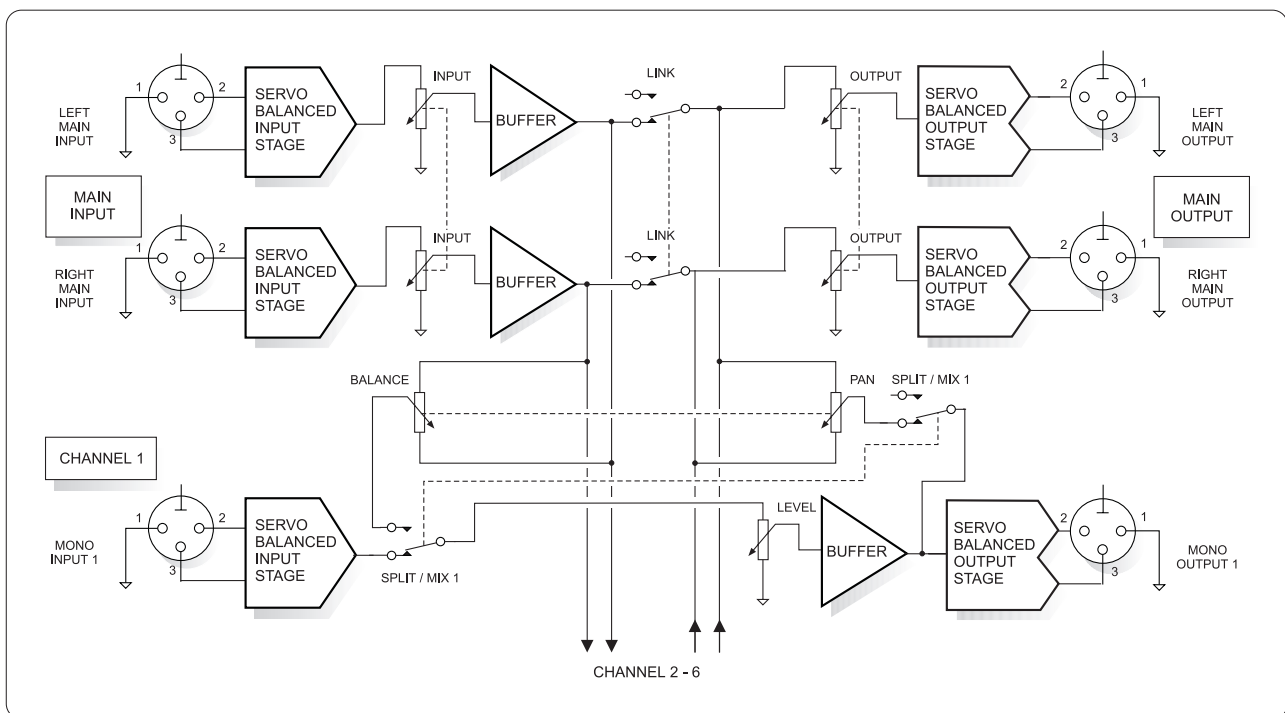

### MAIN Section

Both main inputs interface via the MAIN INPUT LEVEL control with the input bus as well as with the main outputs. The MAIN OUTPUT LEVEL control determines the output level of the signals which are summed by the second bus (i.e., the output bus) and are subsequently routed to the main outputs.

### SPLIT Mode

In SPLIT mode, the main input signal is sent via the BALANCE control to the output buffer amplifiers of the mono channels, with the LEVEL control determining the output level of the respective channel. The maximum gain is +15 dB.

### MIX Mode

In MIX mode, the input signals of the mono channels are "collected" via the LEVEL and PAN controls and are routed to the output bus. In this mode, the LEVEL control determines the amount of each channel at the output

bus, while the PAN control is responsible for the allocation of the input signal to the left and right main outputs.

Additionally, the input signal is routed to the respective mono outputs, i.e., the circuit acts as a matching amplifier. The LEVEL control allows for level compensation of up to +15 dB.

# Specifications

## Audio Inputs

Connectors	XLR and ¼" TRS
Type	RF filtered, servo-balanced input
Impedance	50 kOhms balanced, 25 kOhms unbalanced
Nominal operating level	-10 dBV to +4 dBu
Max. input level	+21 dBu balanced and unbalanced
CMRR	Typ. 40 dB, > 55 dB @ 1 kHz

## Audio Outputs

Connectors	XLR and ¼" TRS
Type	Electronically servo-balanced output stage
Impedance	60 Ohms balanced, 30 Ohms unbalanced
Max. output level	+22 dBu balanced and unbalanced

## System Specifications

Frequency response	5 Hz to 200 kHz, +/-3 dB
S/N ratio	>95 dBu, unweighted, 22 Hz to 22 kHz
THD	0.002% typ. @ +4 dBu, 1kHz, gain 1

## Function Controls

Main input level	variable
Main output level	variable
Level	variable for each channel
Balance/pan	placing in the stereo field

## Function Switches

Main Link	links the main input signal to the main output
Split/mix	changeover from split to mix mode for each channel

## Indicators

Input level (main)	4-digit LED display: -24/-12/0/+6 dB
Output level (main)	4-digit LED display: -24/-12/0/+6 dB
Input/output level	8-digit LED display: -24/-18/-12/-6/0/+6/+12/+18 dB

## Power Supply

### Mains Voltages

USA/Canada	120 V~, 60 Hz
U.K./Australia	240 V~, 50 Hz
Europe	230 V~, 50 Hz
General Export Model	100 - 120 V~, 200 - 240 V~, 50 - 60 Hz
Power Consumption	max. 35 Watts
Fuse	100 - 120 V~: T 630 mA H 200 - 240 V~: T 315 mA H
Mains Connection	Standard IEC receptacle

## Physical/Weight

Dimensions (H x W x D)	approx. 8.5 x 1.75 x 19" approx. 217 x 44.5 x 483 mm
Net Weight	approx. 2.38 kg
Shipping Weight	approx. 3.5 kg

BEHRINGER is constantly striving to maintain the highest professional standards. As a result of these efforts, modifications may be made from time to time to existing products without prior notice. Specifications and appearance may differ from those listed or shown.

TECHNICAL SPECIFICATIONS AND APPEARANCES ARE SUBJECT TO CHANGE WITHOUT NOTICE AND ACCURACY IS NOT GUARANTEED. BEHRINGER IS PART OF THE MUSIC GROUP (MUSIC-GROUP.COM). ALL TRADEMARKS ARE THE PROPERTY OF THEIR RESPECTIVE OWNERS. MUSIC GROUP ACCEPTS NO LIABILITY FOR ANY LOSS WHICH MAY BE SUFFERED BY ANY PERSON WHO RELIES EITHER WHOLLY OR IN PART UPON ANY DESCRIPTION, PHOTOGRAPH OR STATEMENT CONTAINED HEREIN. COLORS AND SPECIFICATIONS MAY VARY FROM ACTUAL PRODUCT. MUSIC GROUP PRODUCTS ARE SOLD THROUGH AUTHORIZED FULLFILLERS AND RESELLERS ONLY. FULLFILLERS AND RESELLERS ARE NOT AGENTS OF MUSIC GROUP AND HAVE ABSOLUTELY NO AUTHORITY TO BIND MUSIC GROUP BY ANY EXPRESS OR IMPLIED UNDERTAKING OR REPRESENTATION. THIS MANUAL IS COPYRIGHTED. NO PART OF THIS MANUAL MAY BE REPRODUCED OR TRANSMITTED IN ANY FORM OR BY ANY MEANS, ELECTRONIC OR MECHANICAL, INCLUDING PHOTOCOPYING AND RECORDING OF ANY KIND, FOR ANY PURPOSE, WITHOUT THE EXPRESS WRITTEN PERMISSION OF MUSIC GROUP IP LTD. ALL RIGHTS RESERVED. © 2012 MUSIC GROUP IP LTD. TRIDENT CHAMBERS, WICKHAMS CAY, P.O. BOX 146, ROAD TOWN, TORTOLA, BRITISH VIRGIN ISLANDS