

Portable PA Systems

EUROPORT EPA900

Ultra-Compact 900-Watt 8-Channel Portable PA System with Digital Effects and FBQ Feedback Detection

- Ultra-compact 900-Watt, 8-channel portable PA system
- Enormous power, incredible sonic performance, and super-light weight means no more lugging around dead weight
- Extremely powerful 10" woofers and 1.35" aluminum-diaphragm compression drivers for incredible sound reproduction
- Studio-grade 24-bit stereo FX processor with 100 awesome presets including reverb, chorus, flanger, delay, pitch shifter and various multi-effects
- Revolutionary FBQ Feedback Detection system instantly reveals critical frequencies for easy feedback removal
- 8-channel mixer section comprises 4 mono and 2 stereo channels plus separate CD inputs
- 4 high-quality mic preamps with switchable +48 V phantom power for condenser microphones
- Effective, extremely musical 2-band EQ, switchable Pad and Clip LEDs on all mono channels
- Stereo 7-band graphic EQ allows precise frequency correction of main outputs
- Voice Canceller function removes singer's voice from recordings for karaoke applications



Looking for the ultimate portable PA system? The new EPA900 from BEHRINGER sets up in less than two minutes and delivers articulate, high-fidelity performance. With its twin 450-Watt amplifiers and custom-designed, 2-way loudspeakers, the EPA900 can fill a medium- to large-sized room or project your voice for an incredible distance outdoors.

All the accessories you'll need are provided (including a microphone, mic and speaker cables) in a convenient, easy to transport and set up package—and the good news is you don't have to be a sound engineer to run it!

Superb Sound Quality

Since we already make some of the best-sounding audio mixers, amplifiers and loudspeakers on the planet, it should

come as no surprise that the EPA900 provides far superior sound quality than other products in this class. The two satellite speakers feature custom-designed 10" woofers and 1.35" aluminum-diaphragm compression drivers for incredible fidelity and clarity you might not expect from a loudspeaker system this small!

Control Freak...

Channels 1–4 feature our high-quality Invisible Mic Preamps (IMP), which have been praised for their transparency and headroom. A Level control is provided with a Clip LED, so you can dial in the perfect signal level. We've also provided a Pad switch for those occasions when you have to contend with "hotter" than normal input levels.

Continued on next page



EUROPORT EPA900

- Dedicated mono output with integrated low-pass filter for subwoofer application
- Stereo Aux inputs for external devices such as sub mixers, etc.
- Comes with a BEHRINGER XM1800S microphone, a mic clip and a 20' cable
- Integrated storage compartment for microphones, cables, and accessories
- "Planet Earth" switching power supply for maximum flexibility (100 - 240 V~), noise-free audio, superior transient response plus low power consumption for energy savings
- High-quality components and exceptionally rugged construction ensure long life
- Conceived and designed by BEHRINGER Germany

Phantom Power is also available, so you can use studio-grade condenser mics. Overall system response is handled by a 7-band stereo graphic EQ, and our proprietary FBQ Feedback Detection System helps you track and eliminate those annoying mic squeals.

Additionally, each input channel has a two-band EQ (Bass and Treble), Balance (allowing you to place the signal wherever you want within the stereo image) and an Effects level control. It is important to note that while many of our competitors only provide a reverb switch, the EPA900 features an FX level control per channel with 100 state-of-the-art 24-bit digital FX to choose from. FX can be turned off/on via any standard footswitch (not included).

The Sweet Sound of Reverb, or Delay, or...

If you're making a speech, chances are you won't need it, but if you're playing a musical instrument and/or singing, you might want to add some effects. So, we've included a 24-bit stereo FX processor with 100 great-sounding presets including reverb, chorus, flanger, delay, pitch shifter and various multi-effects to sweeten your performance. And if you want to sing along with pre-recorded tapes or CDs, the EPA900's Voice Canceller function can remove virtually all the vocals from music played back through channels 7/8 with the simple flick of a switch.

It's All About Connections

The EPA900 comes ready for your input, literally. Channels 1-4 accept balanced XLR mics, as well as balanced and unbalanced 1/4" line-level sources, such as electronic keyboards and the like. Stereo channels 5/6 and 7/8 accommodate RCA and 1/4" inputs, such as drum machines, keyboard sound modules, etc. All in all, there are enough mic and line-level inputs to handle a small band, and the RCA Tape Out connectors provide the perfect connections for recording your performance.

A Bonus Channel?

Want to play some of your favorite tunes at the company picnic? The EPA900 comes equipped with a 1/8" stereo minijack for connecting an MP3 player. Additionally, the Stereo Aux In section features Left and Right 1/4" jacks for connecting even more professional audio sources. You don't even have to give up a channel, just control the volume from the player. It's like getting 10 channels for the price of eight!

Everything You Need

The EPA900 is a complete system. Just use the built-in wheels to roll it from the car to the stage, set the main unit on a tabletop and deploy the speakers. Connect the high-quality dynamic microphone and hit the power switch—voilà, instant PA system! There is

Continued on next page

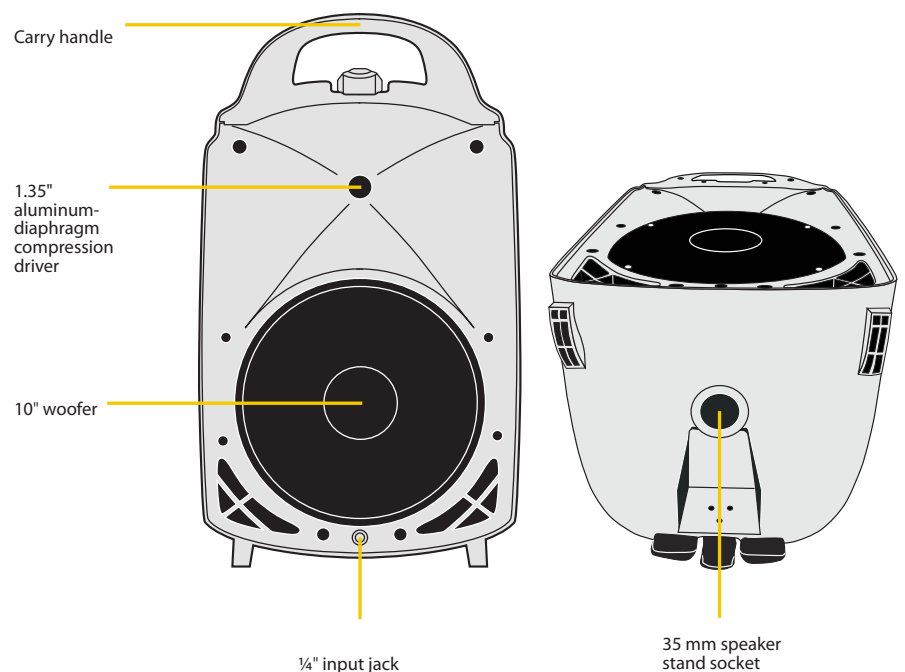

EUROPORT EPA900

even an onboard storage compartment for the included microphone, accessories and cables. And if you need to add some serious bottom-end to your system, just connect an active subwoofer to the handy Sub Out jack.

Value

Whether you're pounding out original music in your garage, or cranking it up at the neighborhood bar, we think you will agree the EPA900 provides extreme value as a complete, portable PA solution. Compare it to the competition and you'll own BEHRINGER.

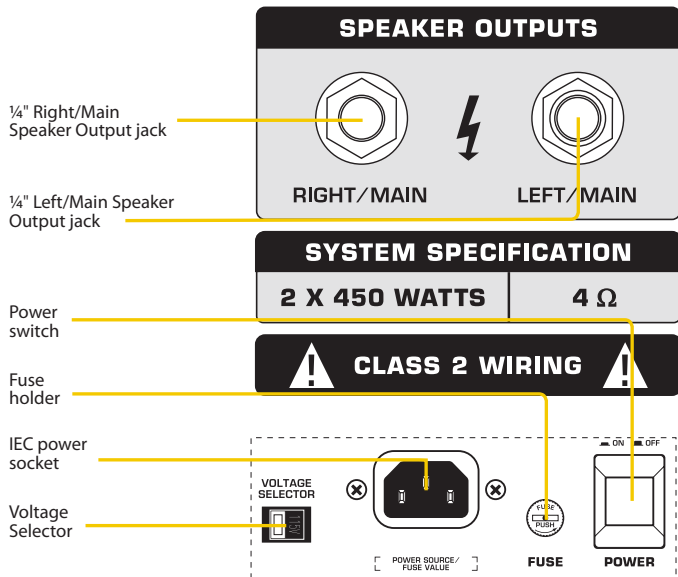
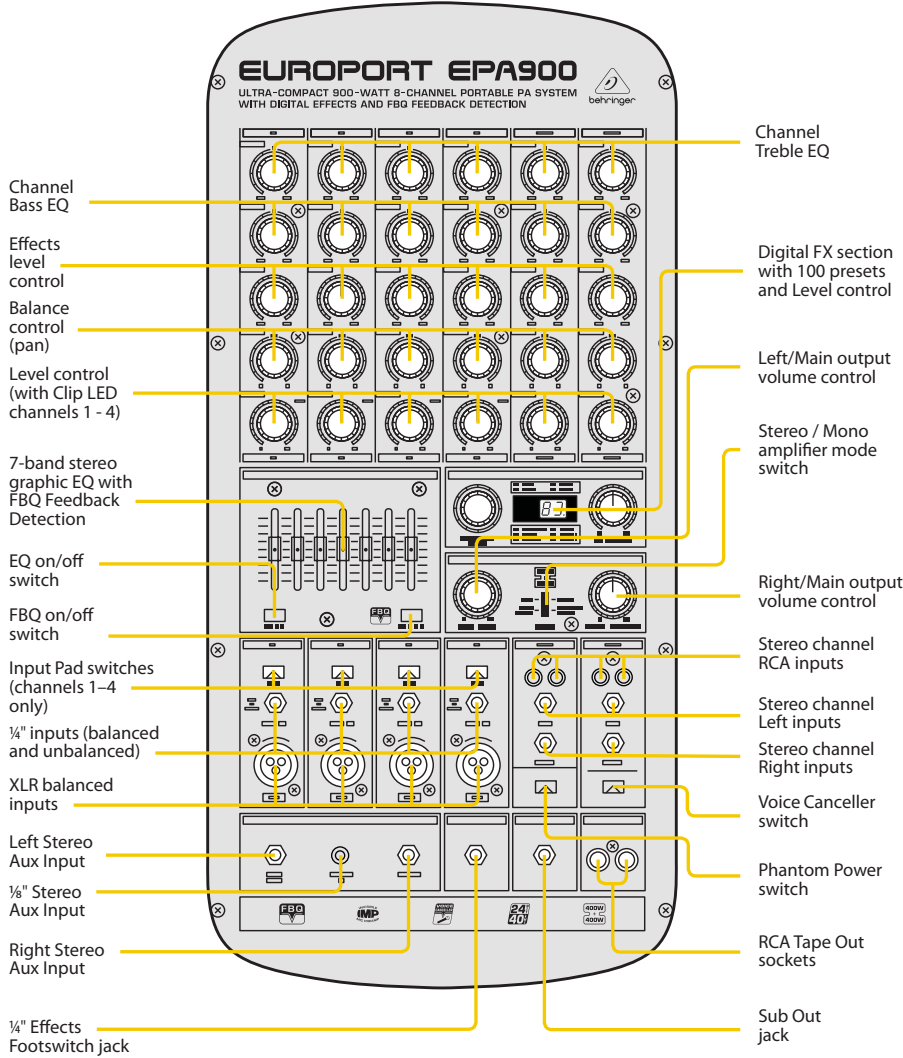

The EPA900 packs into a suitcase-style roll-away, complete with its own casters.

EUROPORT EPA900

Live Performance Setup

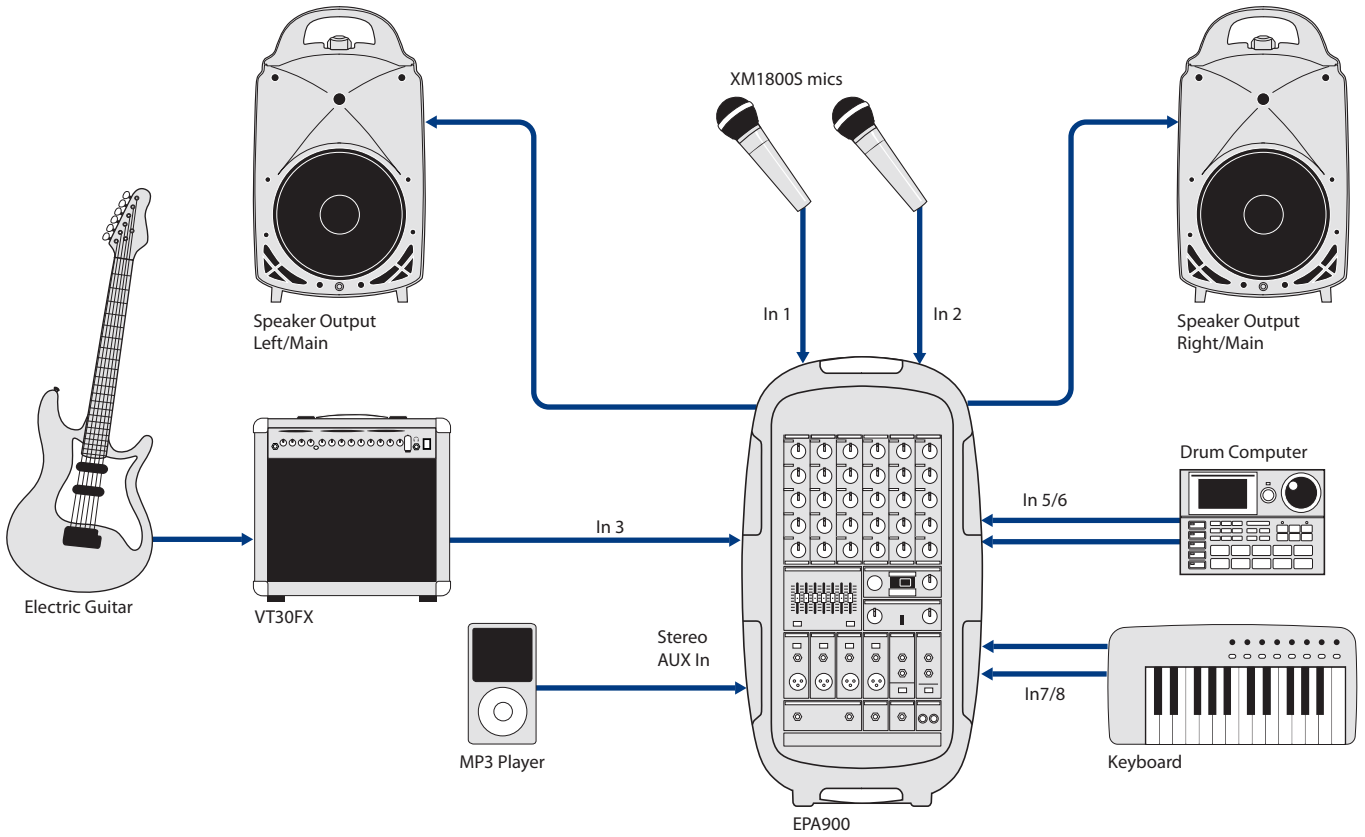

Business Presentation Setup

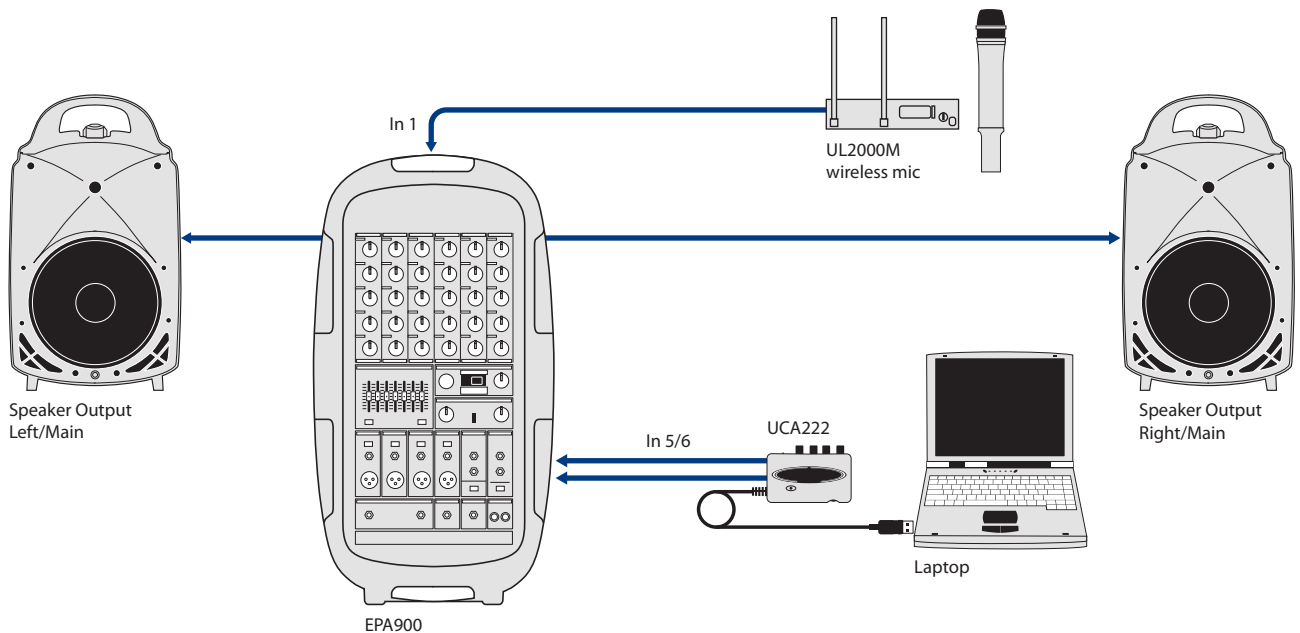

EUROPORT EPA900

INPUTS 1-4

Type	4 x XLR, electronically balanced 4 x ¼" TRS jack, electronically balanced
Impedance	approx 2.2 kΩ , balanced, approx 1.1 kΩ , unbalanced
Input sensitivity	- 21 dBu @ PAD/OFF
Max. gain	+ 30 dB to + 10 dB
Phantom power supply	+ 48 V
Signal-to-noise ratio	- 90 dB, A-weighted
Channel separation	70 dB

INPUTS 5-8

Type	4 x ¼" TS jack, unbalanced 4 x RCA jack, unbalanced
Impedance	approx. 20 kΩ , unbalanced
Input sensitivity	- 15 dBu
Max. gain	+ 20 dB
Signal-to-noise ratio	- 85 dB, A-weighted

STEREO AUX IN

Type	1 x ¼" TS jack, unbalanced 1 x stereo minijack, unbalanced
Impedance	100 kΩ , unbalanced
Input sensitivity	- 8 dBu
Signal-to-noise ratio	- 90 dB, A-weighted

TAPE OUT

Type	2 x RCA, unbalanced
Impedance	approx 1 kΩ
Max. output level	+ 17 dBu, unbalanced
Channel separation	> 70 dB

SUB OUT

Type	1 x ¼" mono jack, unbalanced
Impedance	approx. 1 kΩ
Max. output level	+ 21 dBu, unbalanced

CHANNEL EQ

BASS	± 15 dB @ 80 Hz
TREBLE	± 15 dB @ 12 kHz

EFFECTS

Converter	24-bit delta-sigma
Sampling frequency	40 kHz
Display	2-digit, 7-segment

EQ

Type	7-band
------	--------

LOUDSPEAKER OUTPUTS

Type	2 x ¼" TS jack
Load impedance	8 Ω

OUTPUT POWER

RMS (@ 8 Ω)	2 x 160 Watts
RMS (@ 4 Ω)	2 x 300 Watts
Peak power (@ 8 Ω)	2 x 260 Watts
Peak power (@ 4 Ω)	2 x 450 Watts

SYSTEM SPECIFICATIONS

Frequency response	50 Hz to 20 kHz, ± 3 dB
Distortion (THD + N)	0.32% @ 1 W

POWER SUPPLY

Power consumption	1,000 W
Fuse	T 10 A H 250 V (100 – 120 V~, 50/60 Hz) T 10 A H 250 V 220 – 240 V~, 50/60 Hz)

DIMENSIONS/WEIGHT

Dimensions (H x W x D)	approx. 26.0 x 13.9 x 34.8" approx. 660 x 354 x 883 mm
Weight	approx. 68.34 lbs/approx. 31 kg

Please note these specifications are preliminary and conceptual in nature, and as such are subject to change as product development progresses. This information is supplied for market research purposes only and is not to be made public in any manner. This document is solely the property of The MUSIC Group, or one of its subsidiaries, and must be surrendered upon request of the owner.

For service, support or more information contact the BEHRINGER location nearest you:

Europe Tel.: +49 2154 9206 4149
Fax: +49 2154 9206 4199

USA/Canada Tel.: +1 425 672 0816
Fax: +1 425 673 7647

Singapore Tel.: +65 6845 1800
Fax: +65 6214 0275

Australia Tel.: +61 03 9877 7170
Fax: +61 03 9877 7870

Japan Tel.: +81 3 5281 1180
Fax: +81 3 5281 1181

©2011 Red Chip Company Ltd. Technical specifications and appearance subject to change without notice. The information contained herein is correct at the time of printing. All trademarks are the property of their respective owners. BEHRINGER accepts no liability for any loss which may be suffered by any person who relies either wholly or in part upon any description, photograph or statement contained herein. 85-10000-00420

behringer.com

