

# Professional Passive Speakers

## EUROLIVE B215XL/B212XL B215XL-WH/B212XL-WH

### EUROLIVE - 1000-Watt/800-Watt 2-Way PA Speaker System with 15"/12" Woofer and 1.75" Titanium Compression Driver

- High-power 2-way PA sound reinforcement speaker system for live and playback applications (200 Watts Continuous / 800 Watts Peak Power and 250 Watts Continuous / 1000 Watts Peak Power)
- Available in black or white finish
- Ultra-compact and light weight system delivers excellent sound even at extreme sound pressure levels
- Extremely powerful 15"/12" long-excursion driver provides incredibly deep bass and acoustic power
- State-of-the-art 1.75" titanium-diaphragm compression driver for exceptional high-frequency reproduction
- Ultra-wide dispersion, large-format exponential horn
- Overload-protection circuitry ensures optimal HF driver protection
- Versatile trapezoidal enclosure design allows different positioning:
- Stand mounting with 35-mm pole socket
- Tilts on its side for use as a floor monitor
- Optional swiveling mounting brackets available (sold separately)



These loudspeakers take everything musicians love about the original B212 and B215 loudspeakers and upgrade them with the same bass and treble drivers found in our wildly popular B212A/B215A active versions for even better sound and power handling. And with integrated overload protection circuitry, these loudspeakers arrive ready to push it to the limit without putting their high-or low-frequency drivers in danger.

#### Triumphant transducers

Every stitch of these loudspeakers is built to deliver, but the fact is that their transducers (woofers and tweeters) are the only part you actually hear. While some manufacturers are okay with putting off-the-shelf transducers in their boxes, we custom-design and build ours from scratch. Not only do we wind our own voice coils, we grow

the trees that are processed into the paper pulp that becomes the cones. We even machine the frames and backplates. BEHRINGER's quality is truly under control.

#### Big sound, lightweight, low price

Big here, small there, lots of this, light on that—everyone's got their preferences, but the EUROLIVE B212XL and B215XL have proportions we can all agree upon. These loudspeakers pack a clean, punchy wallop (and can handle up to 800 and 1000 Watts, respectively), they are easy to lift by their recessed handles (24 lbs / 38.7 lbs) and are available at insanely low prices. Who wouldn't want to hook up with one of these beauties?

*Continued on page 3*



# EUROLIVE B215XL/B212XL B215XL-WH B212XL-WH

- Ergonomically shaped handles for easy carrying and setup
- 2 professional speaker connectors plus 1/4" jack connectors
- High-quality components and exceptionally rugged construction ensure long life
- Conceived and designed by BEHRINGER Germany

## Stereo separation with a subwoofer

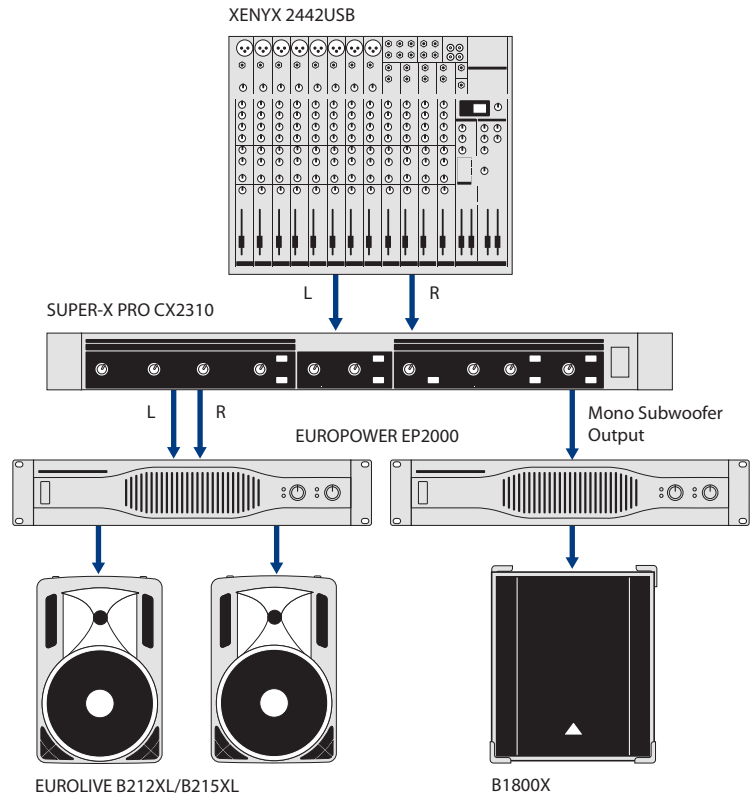

## Wiring several B212XL/B215XL loudspeakers

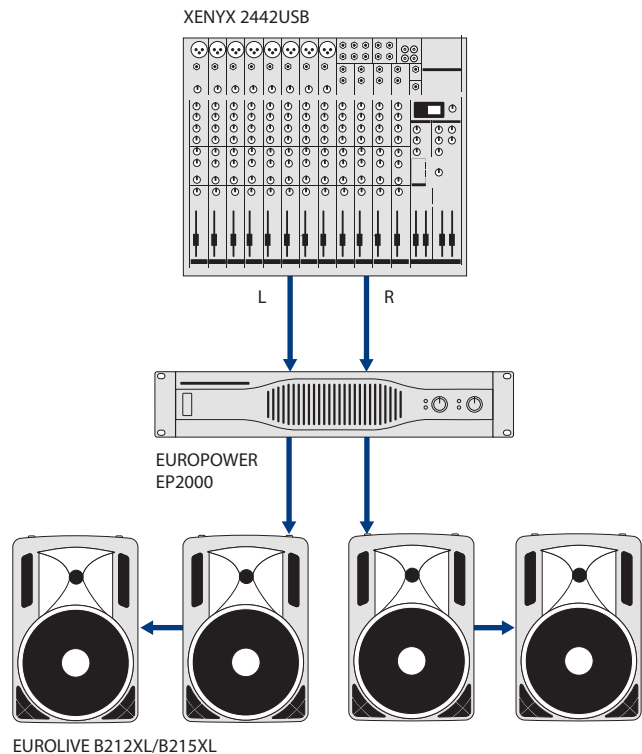

# EUROLIVE B215XL/B212XL B215XL-WH B212XL-WH

### Get on the stick...or get on down

The B212XL and B215XL are perfect either as part of a PA system or as onstage monitors. If the situation calls for a PA, mount the speakers on stands via the 35mm pole socket. From there, send a line from the MAIN OUT of a mixer (such as a XENYX 1202FX) to a power amplifier (like the EUROPOWER EP2000). Finally, attach a B212XL or B215XL to each of the amp's outputs. These loudspeakers have inputs for both professional speaker cable and 1/4" cable. Because these loudspeakers have two parallel inputs, you can connect up to two of them to any channel on a power amp.

But these loudspeakers don't have to be confined to an upright position. Just lay them on their sides for use as a floor monitor. You'll find that they tilt to the ideal angle for onstage monitor wedge applications.

### Choose white, black, on or off the wall...

You asked for it, and now we're proud to offer these amazing loudspeakers in black or white. We now also make swiveling wall-mount brackets for the B212XL and B215XL. That means they're ready to fit even more comfortably into a venue's color scheme and layout (WB212 and WB215 for black brackets or WB212-WH and WB215-WH for white). No matter what your sound or aesthetic needs may be, we make one that's just right for you!

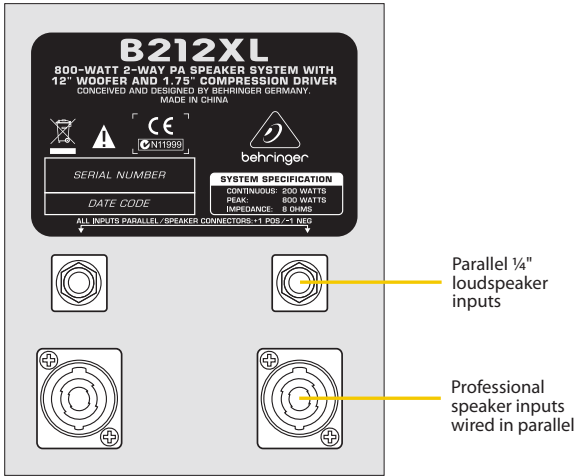
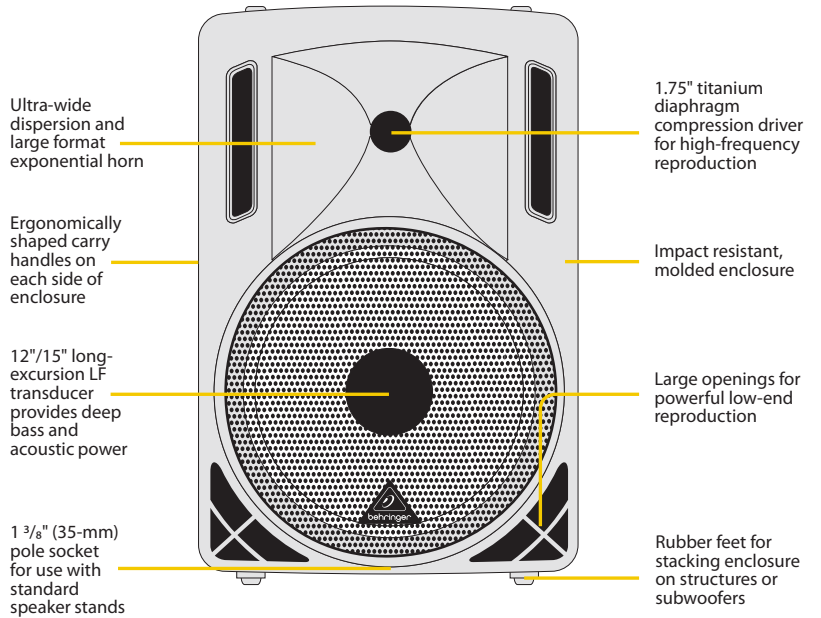

## B212XL

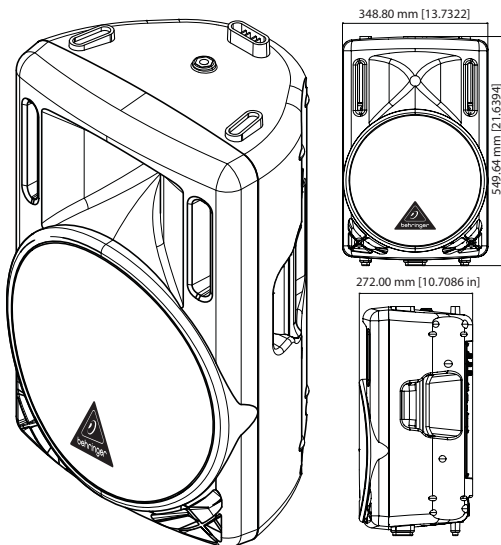

## B215XL

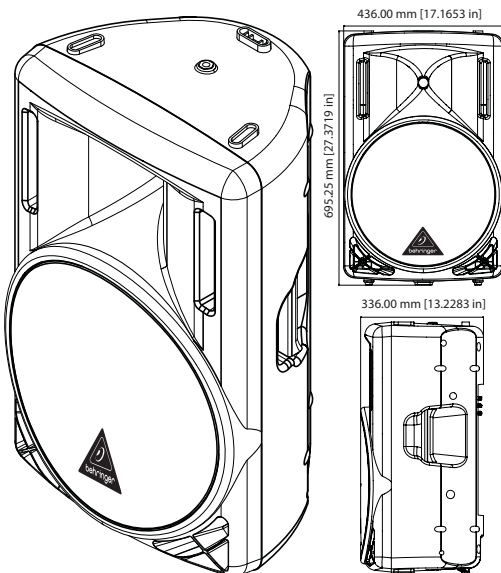

# EUROLIVE B215XL/B212XL B215XL-WH B212XL-WH

## SYSTEM DATA

### B215XL

High-performance woofer 15" (381 mm)

### B212XL

High-performance woofer 12" (305 mm)

### B215XL / B212XL

Tweeter compression driver 1.75" (44 mm)

### B215XL

Frequency range 55 Hz to 20 kHz

### B212XL

Frequency range 65 Hz to 18 kHz

### B215XL

Power rating 1000 W Peak Power 250 W  
Continuous Power (IEC 60268-5)

### B212XL

Power rating 800 W Peak Power 200 W  
Continuous Power (IEC 60268-5)

## B215XL / B212XL

Impedance 8  $\Omega$

### B215XL

Sensitivity (1 W @ 1 m) 96 dB (Full Space)

### B212XL

Sensitivity (1 W @ 1 m) 95 dB (Full Space)

### B215XL

Dispersion 70° x 40°

### B212XL

Dispersion 90° x 60°

### B215XL

Crossover frequency 2.0 kHz

### B212XL

Crossover frequency 1.9 kHz

## DIMENSIONS/WEIGHT

### B215XL

Dimensions (HxWxD) approx. 27 1/2 x 17 1/2 x 13 1/16"  
approx. 695 x 440 x 335 mm

Weight 38.7 lbs/17.6 kg

### B212XL

Dimensions (HxWxD) approx. 21 2/3 x 13 3/8 x 10 3/8"  
approx. 550 x 345 x 270 mm

Weight 24.0 lbs/10.9 kg

Please note these specifications are preliminary and conceptual in nature, and as such are subject to change as product development progresses. This information is supplied for market research purposes only and is not to be made public in any manner. This document is solely the property of The MUSIC Group, or one of its subsidiaries, and must be surrendered upon request of the owner.

For service, support or more information contact the BEHRINGER location nearest you:

**Europe** Tel.: +49 2154 9206 4149  
Fax: +49 2154 9206 4199

**USA/Canada** Tel.: +1 425 672 0816  
Fax: +1 425 673 7647

**Singapore** Tel.: +65 6845 1800  
Fax: +65 6214 0275

**Australia** Tel.: +61 03 9877 7170  
Fax: +61 03 9877 7870

**Japan** Tel.: +81 3 5281 1180  
Fax: +81 3 5281 1181

©2011 Red Chip Company Ltd. Technical specifications and appearance subject to change without notice. The information contained herein is correct at the time of printing. All trademarks are the property of their respective owners. BEHRINGER accepts no liability for any loss which may be suffered by any person who relies either wholly or in part upon any description, photograph or statement contained herein. 985-10000-00350

behringer.com

